

NMSU Astronomy
ASTR 1115G
Lab Manual

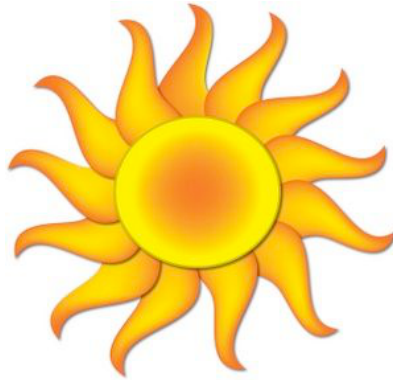

ASTR1115G - Dr. Jackiewicz
SPRING 2025
©NMSU Astronomy

Contents

1	Tools for Success in ASTR 1115G	1
2	Optics	17
3	The Power of Light: Understanding Spectroscopy	31
4	Measuring Distances Using Parallax	45
5	Characterizing Exoplanets	56
6	The Hertzsprung-Russell Diagram	76
7	Our Sun	92
8	Mapping the Galaxy	106
9	Galaxy Morphology	120
10	How Many Galaxies are there in the Universe?	140
11	Hubble's Law: Finding the Age of the Universe	151
12	APPENDIX A: Fundamental Quantities	161
13	APPENDIX B: Accuracy and Significant Digits	162
14	APPENDIX C: Unit Conversions	163
15	APPENDIX D: Uncertainties and Errors	164
16	Observatory Worksheets	165

Name: _____

Date: _____

1 Tools for Success in ASTR 1115G

1.1 Introduction

Astronomy is a physical science. Just like biology, chemistry, geology, and physics, astronomers collect data, analyze that data, attempt to understand the object/subject they are looking at, and submit their results for publication. Along the way astronomers use all of the mathematical techniques and physics necessary to understand the objects they examine. Thus, just like any other science, a large number of mathematical tools and concepts are needed to perform astronomical research. In today's introductory lab, you will review and learn some of the most basic concepts necessary to enable you to successfully complete the various laboratory exercises you will encounter during this semester. When needed, the weekly laboratory exercise you are performing will refer back to the examples in this introduction—so keep the completed examples you will do today with you at all times during the semester to use as a reference when you run into these exercises later this semester (in fact, on some occasions your TA might have you redo one of the sections of this lab for review purposes).

1.2 A Note About Ratios

You will encounter ratios in many of your classes, cooking, recipes, money transactions, etc.! A ratio simply indicates how many times one number contains the other number. For example, if I had a bowl of fruit with 8 apples and 6 bananas, the ratio of apples to bananas would be eight to six (or we could say 8:6. Which is equal to 4:3). We know this bowl of fruit has 14 total fruit in it. So we know that there is 8 apples out of the total of 14 fruit, or a ratio of 8:14 (which is equal to a ratio of 4:7. Which we are able to get by noting that both "8" and "14" have something in common! They can be divided by 2!).

Additionally, if I take the ratio 8:14 and I divide 8 by 14 I would get 0.57 (or 57%). From knowing the ratio of apples to total number of fruit in the bowl, I know there are 57% apples. Similarly, we said that the ratio of 8:14 was similar to 4:7. If we did the same thing by dividing 4 by 7, we would also get 0.57 (or 57%)! Which makes sense since we said they were equal!!

In fact, a ratio may be considered as an ordered pair of numbers, or a fraction! The first number in a ratio would be the numerator of a fraction. And the second number in the ratio would be the denominator.

Ratios may be quantities of any kind! They can be counts of people or objects! These ratios can be lengths, weights, time, etc.

Practice with ratios:

Remember, a ratio compares two different quantities. Those two quantities can be anything. In your astronomy labs they will most likely be comparing two distances, lengths, or

time. The order of a ratio matters!

1. If you drive for 60 miles in 2 hours, how fast were you driving? Show how you figured this out! (**1 points**)

This is a common use of ratios (and proportions). This is comparing the number of miles (60) to the number of hours it took to drive (2). So the ratio is 60:2 (which we would verbal express as “60 miles in 2 hours”).

2. Now let’s say you rode your bike at a rate of 10 miles per hour for 4 hours. How many miles did you travel? Show your work with how you solved it. (**2 points**)

We know our ratio is 10:1 (10 miles per 1 hour). So that tells us that in 4 hours, we will have traveled a total of 40 miles.

3. Looking ahead to the scale model lab, we will place all the planets on the Football field with Pluto at the 100 yard line. One of the instructions asks you to figure out how many yards there are per AU based on the fact that Pluto is at the 100 yard line (an AU is an Astronomical Unit which is the average distance between the sun and Earth). We know that Pluto is 40 AU away in space. So if we were to “scale” down the distance to yards on a football field, we know that there would be a ratio of 100 yards to AU. Similar to the miles per hour example above, how many yards per AU is there in a “Scale Model” of the solar system? (**2 points**)

1.3 The Metric System

Like all other scientists, astronomers use the metric system. The metric system is based on powers of 10, and has a set of measurement units analogous to the English system we use in everyday life here in the US. In the metric system the main unit of length (or distance) is the *meter*, the unit of mass is the *kilogram*, and the unit of liquid volume is the *liter*. A meter is approximately 40 inches, or about 4" longer than the yard. Thus, 100 meters is about 111 yards. A liter is slightly larger than a quart (1.0 liter = 1.101 qt). On the Earth's surface, a kilogram = 2.2 pounds.

As you have almost certainly learned, the metric system uses prefixes to change scale. For example, one thousand meters is one "kilometer." One thousandth of a meter is a "millimeter." The prefixes that you will encounter in this class are listed in Table 1.3.

Table 1.1: Metric System Prefixes

Prefix Name	Prefix Symbol	Prefix Value
Giga	G	1,000,000,000 (one billion)
Mega	M	1,000,000 (one million)
kilo	k	1,000 (one thousand)
centi	c	0.01 (one hundredth)
milli	m	0.001 (one thousandth)
micro	μ	0.0000001 (one millionth)
nano	n	0.0000000001 (one billionth)

In the metric system, 3,600 meters is equal to 3.6 kilometers; 0.8 meter is equal to 80 centimeters, which in turn equals 800 millimeters, etc. In the lab exercises this semester we will encounter a large range in sizes and distances. For example, you will measure the sizes of some objects/things in class in millimeters, talk about the wavelength of light in nanometers, and measure the sizes of features on planets that are larger than 1,000 kilometers.

1.4 Beyond the Metric System

When we talk about the sizes or distances to objects beyond the surface of the Earth, we begin to encounter very large numbers. For example, the average distance from the Earth to the Moon is 384,000,000 meters or 384,000 kilometers (km). The distances found in astronomy are usually so large that we have to switch to a unit of measurement that is much larger than the meter, or even the kilometer. In and around the solar system, astronomers use "Astronomical Units." An Astronomical Unit is the mean (average) distance between the Earth and the Sun. One Astronomical Unit (AU) = 149,600,000 km. For example, Jupiter is about 5 AU from the Sun, while Pluto's average distance from the Sun is 39 AU. With this change in units, it is easy to talk about the distance to other planets. It is more convenient to say that Saturn is 9.54 AU away than it is to say that Saturn is 1,427,184,000 km from Earth.

1.5 Changing Units and Scale Conversion

Changing units (like those in the previous paragraph) and/or scale conversion is something you must master during this semester. You already do this in your everyday life whether you know it or not (for example, if you travel to Mexico and you want to pay for a Coke in pesos), so **do not panic!** Let's look at some examples (**2 points each**):

1. Convert 34 meters into centimeters:

Answer: Since one meter = 100 centimeters, 34 meters = 3,400 centimeters.

2. Convert 34 kilometers into meters:

3. If one meter equals 40 inches, how many meters are there in 400 inches?

4. How many centimeters are there in 400 inches?

5. In August 2003, Mars made its closest approach to Earth for the next 50,000 years. At that time, it was only about .373 AU away from Earth. How many km is this?

1.5.1 Map Exercises

One technique that you will use this semester involves measuring a photograph or image with a ruler, and converting the measured number into a real unit of size (or distance). One example of this technique is reading a road map. Figure 1.1 shows a map of the state of New Mexico. Down at the bottom left hand corner of the map is a scale in both miles and kilometers.

Use a ruler to determine (**2 points each**):

6. How many kilometers is it from Las Cruces to Albuquerque?

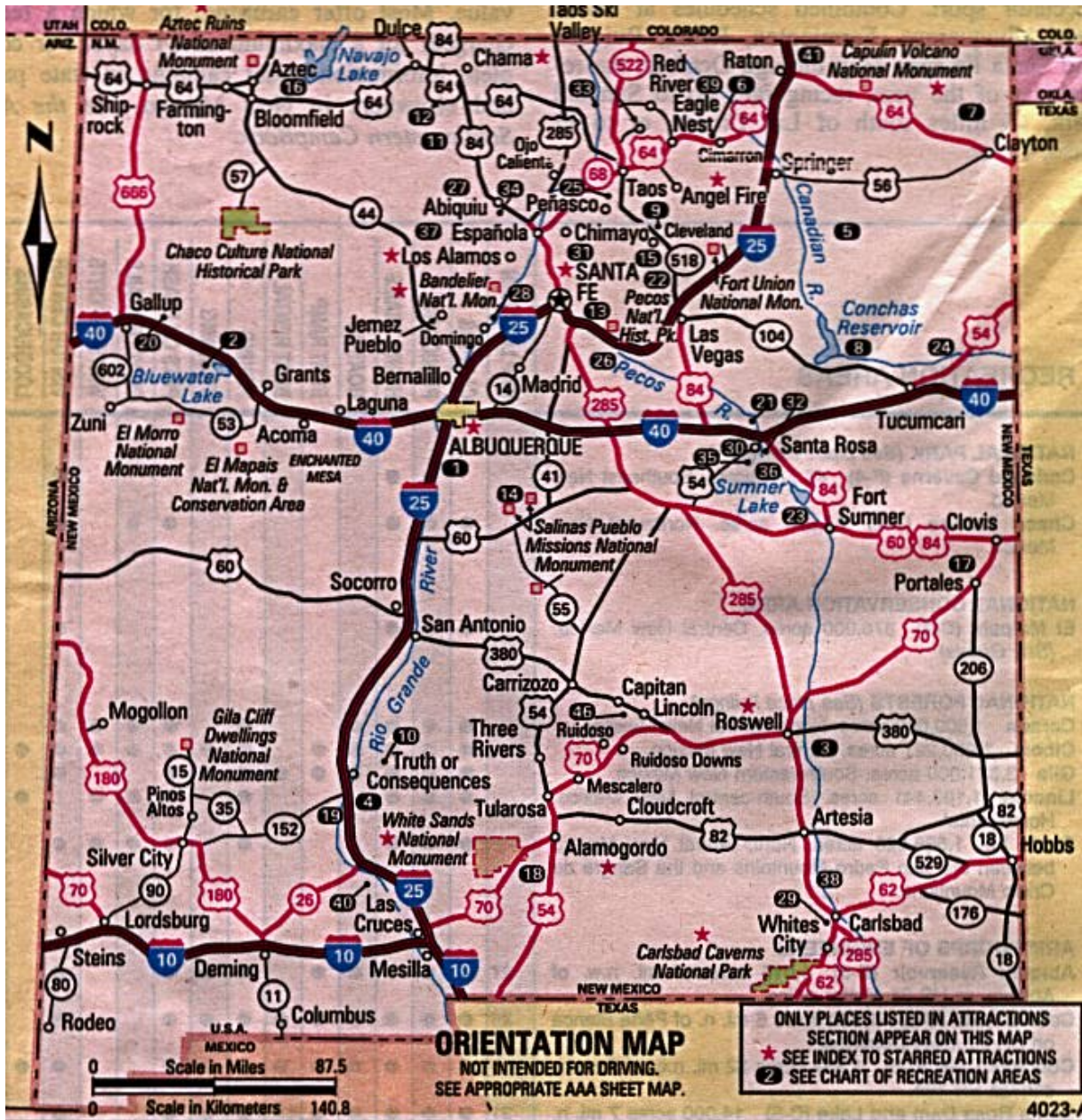

Figure 1.1: Map of New Mexico.

7. What is the distance in miles from the border with Arizona to the border with Texas if you were to drive along I-40?

8. If you were to drive 100 km/hr (kph), how long would it take you to go from Las Cruces to Albuquerque?

9. If one mile = 1.6 km, how many miles per hour (mph) is 100 kph?

1.6 Squares, Square Roots, and Exponents

In several of the labs this semester you will encounter squares, cubes, and square roots. Let us briefly review what is meant by such terms as squares, cubes, square roots and exponents. The square of a number is simply that number times itself: $3 \times 3 = 3^2 = 9$. The *exponent* is the little number “2” above the three. $5^2 = 5 \times 5 = 25$. The exponent tells you how many times to multiply that number by itself: $8^4 = 8 \times 8 \times 8 \times 8 = 4096$. The square of a number simply means the exponent is 2 (three squared = 3^2), and the cube of a number means the exponent is three (four cubed = 4^3). Here are some examples:

- $7^2 = 7 \times 7 = 49$

- $7^5 = 7 \times 7 \times 7 \times 7 \times 7 = 16,807$

- The cube of 9 (or “9 cubed”) = $9^3 = 9 \times 9 \times 9 = 729$

- The exponent of 12^{16} is 16

- $2.56^3 = 2.56 \times 2.56 \times 2.56 = 16.777$

Your turn (2 points each):

10. $6^3 =$

11. $4^4 =$

12. $3.1^2 =$

The concept of a square root is fairly easy to understand, but is much harder to calculate (we usually have to use a calculator). The square root of a *number* is that number whose square is the *number*: the square root of $4 = 2$ because $2 \times 2 = 4$. The square root of 9 is 3 ($9 = 3 \times 3$). The mathematical operation of a square root is usually represented by the symbol “ $\sqrt{\quad}$ ”, as in $\sqrt{9} = 3$. But mathematicians also represent square roots using a *fractional* exponent of one half: $9^{1/2} = 3$. Likewise, the cube root of a number is represented as $27^{1/3} = 3$ ($3 \times 3 \times 3 = 27$). The fourth root is written as $16^{1/4} (= 2)$, and so on. Here are some example problems:

- $\sqrt{100} = 10$
- $10.5^3 = 10.5 \times 10.5 \times 10.5 = 1157.625$
- Verify that the square root of 17 ($\sqrt{17} = 17^{1/2}$) = 4.123

1.7 Scientific Notation

The range in numbers encountered in Astronomy is enormous: from the size of subatomic particles, to the size of the entire universe. You are certainly comfortable with numbers like ten, one hundred, three thousand, ten million, a billion, or even a trillion. But what about a number like one million trillion? Or, four thousand one hundred and fifty six million billion? Such numbers are too cumbersome to handle with words. Scientists use something called “Scientific Notation” as a short hand method to represent very large and very small numbers. The system of scientific notation is based on the number 10. For example, the number $100 = 10 \times 10 = 10^2$. In scientific notation the number 100 is written as 1.0×10^2 . Here are some additional examples:

- Ten = $10 = 1 \times 10 = 1.0 \times 10^1$
- One hundred = $100 = 10 \times 10 = 10^2 = 1.0 \times 10^2$
- One thousand = $1,000 = 10 \times 10 \times 10 = 10^3 = 1.0 \times 10^3$
- One million = $1,000,000 = 10 \times 10 \times 10 \times 10 \times 10 \times 10 = 10^6 = 1.0 \times 10^6$

Ok, so writing powers of ten is easy, but how do we write 6,563 in scientific notation? $6,563 = 6563.0 = 6.563 \times 10^3$. To figure out the exponent on the power of ten, we simply count the numbers to the *left* of the decimal point, but do not include the left-most number. Here are some more examples:

- $1,216 = 1216.0 = 1.216 \times 10^3$
- $8,735,000 = 8735000.0 = 8.735000 \times 10^6$
- $1,345,999,123,456 = 1345999123456.0 = 1.345999123456 \times 10^{12} \approx 1.346 \times 10^{12}$

Note that in the last example above, we were able to eliminate a lot of the “unnecessary” digits in that very large number. While $1.345999123456 \times 10^{12}$ is technically correct as the scientific notation representation of the number 1,345,999,123,456, we do not need to keep **all** of the digits to the right of the decimal place. We can keep just a few, and approximate that number as 1.346×10^{12} .

Your turn! Work the following examples (2 points each):

13. $121 = 121.0 =$

14. $735,000 =$

15. $999,563,982 =$

Now comes the sometimes confusing issue: writing very small numbers. First, let's look at powers of 10, but this time in fractional form. The number $0.1 = \frac{1}{10}$. In scientific notation we would write this as 1×10^{-1} . The negative number in the exponent is the way we write the fraction $\frac{1}{10}$. How about 0.001? We can rewrite 0.001 as $\frac{1}{10} \times \frac{1}{10} \times \frac{1}{10} = 0.001 = 1 \times 10^{-3}$. Do you see where the exponent comes from? Starting at the decimal point, we simply count over to the *right* of the first digit that isn't zero to determine the exponent. Here are some examples:

- $0.121 = 1.21 \times 10^{-1}$
- $0.000735 = 7.35 \times 10^{-4}$

- $0.0000099902 = 9.9902 \times 10^{-6}$

Your turn (2 points each):

16. $0.0121 =$

17. $0.0000735 =$

18. $0.000000999 =$

19. $-0.121 =$

There is one issue we haven't dealt with, and that is *when* to write numbers in scientific notation. It is kind of silly to write the number 23.7 as 2.37×10^1 , or 0.5 as 5.0×10^{-1} . You use scientific notation when it is a more compact way to write a number to insure that its value is quickly and easily communicated to someone else. For example, if you tell someone the answer for some measurement is 0.0033 meter, the person receiving that information has to count over the zeros to figure out what that means. It is better to say that the measurement was 3.3×10^{-3} meter. But telling someone the answer is 215 kg, is much easier than saying 2.15×10^2 kg. It is common practice that numbers bigger than 10,000 or smaller than 0.01 are best written in scientific notation.

1.8 Calculator Issues

Since you will be using calculators in nearly all of the labs this semester, you should become familiar with how to use them for functions beyond simple arithmetic.

1.8.1 Scientific Notation on a Calculator

Scientific notation on a calculator is usually designated with an "E." For example, if you see the number 8.778046E11 on your calculator, this is the same as the number 8.778046×10^{11} . Similarly, 1.4672E-05 is equivalent to 1.4672×10^{-5} .

Entering numbers in scientific notation into your calculator depends on layout of your calculator; we cannot tell you which buttons to push without seeing your specific calculator. However, the "E" button described above is often used, so to enter 6.589×10^7 , you may need to type 6.589 "E" 7.

Verify that you can enter the following numbers into your calculator:

- 7.99921×10^{21}

- 2.2951324×10^{-6}

1.8.2 Order of Operations

When performing a complex calculation, the order of operations is extremely important. There are several rules that need to be followed:

- Calculations must be done from left to right.
- Calculations in brackets (parenthesis) are done first. When you have more than one set of brackets, do the inner brackets first.
- Exponents (or radicals) must be done next.
- Multiply and divide in the order the operations occur.
- Add and subtract in the order the operations occur.

If you are using a calculator to enter a long equation, when in doubt as to whether the calculator will perform operations in the correct order, apply parentheses.

Use your calculator to perform the following calculations (**2 points each**):

20. $\frac{(7+34)}{(2+23)} =$

21. $(4^2 + 5) - 3 =$

22. $20 \div (12 - 2) \times 3^2 - 2 =$

1.9 Graphing and/or Plotting

Now we want to discuss graphing data. You probably learned about making graphs in high school. Astronomers frequently use graphs to plot data. You have probably seen all sorts of graphs, such as the plot of the performance of the stock market shown in Fig. 1.2. A plot like this shows the history of the stock market versus time. The “x” (horizontal) axis represents time, and the “y” (vertical) axis represents the value of the stock market. Each place on the curve that shows the performance of the stock market is represented by two numbers, the date (x axis), and the value of the index (y axis). For example, on May 10 of 2004, the Dow Jones index stood at 10,000.

Plots like this require two data points to represent each point on the curve or in the plot. For comparing the stock market you need to plot the value of the stocks versus the date. We call data of this type an “ordered pair.” Each data point requires a value for x (the date)

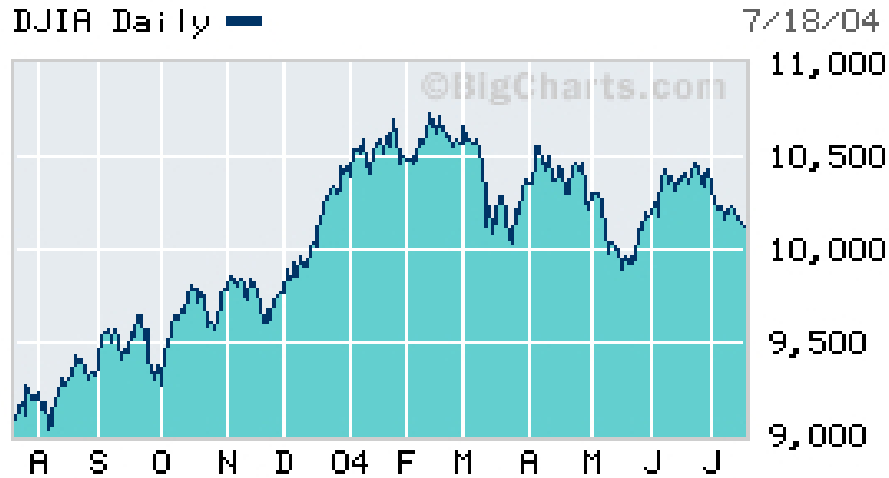

Figure 1.2: The change in the Dow Jones stock index over one year (from April 2003 to July 2004).

Table 1.2: Temperature vs. Altitude

Altitude (feet)	Temperature °F
0	59.0
2,000	51.9
4,000	44.7
6,000	37.6
8,000	30.5
10,000	23.3
12,000	16.2
14,000	9.1
16,000	1.9

and y (the value of the Dow Jones index).

Table 1.2 contains data showing how the temperature changes with altitude near the Earth's surface. As you climb in altitude, the temperature goes down (this is why high mountains can have snow on them year round, even though they are located in warm areas). The data points in this table are plotted in Figure 1.3.

1.9.1 The Mechanics of Plotting

When you are asked to plot some data, there are several things to keep in mind.

First of all, the plot axes **must be labeled**. This will be emphasized throughout the

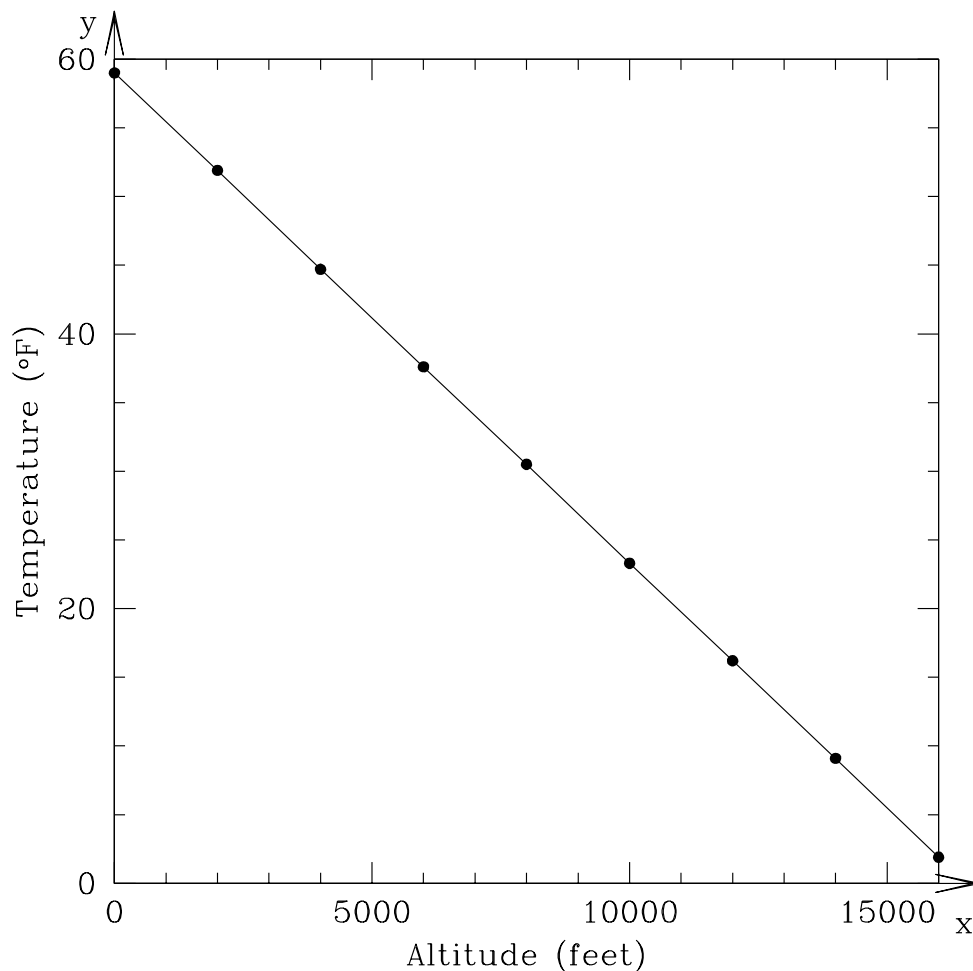

Figure 1.3: The change in temperature as you climb in altitude with the data from Table 1.2. At sea level (0 ft altitude) the surface temperature is 59°F. As you go higher in altitude, the temperature goes down.

semester. In order to quickly look at a graph and determine what information is being conveyed, it is imperative that both the x-axis and y-axis have labels.

Secondly, if you are creating a plot, choose the numerical range for your axes such that the data fit nicely on the plot. For example, if you were to plot the data shown in Table 1.2, with altitude on the y-axis, you would want to choose your range of y-values to be something like 0 to 18,000. If, for example, you drew your y-axis going from 0 to 100,000, then all of the data would be compressed towards the lower portion of the page. It is important to choose your *ranges* for the x and y axes so they bracket the data points.

1.9.2 Plotting and Interpreting a Graph

Table 1.3 contains hourly temperature data on January 19, 2006, for two locations: Tucson and Honolulu.

Table 1.3: Hourly Temperature Data from 19 January 2006

Time hh:mm	Tucson Temp. °F	Honolulu Temp. °F
00:00	49.6	71.1
01:00	47.8	71.1
02:00	46.6	71.1
03:00	45.9	70.0
04:00	45.5	72.0
05:00	45.1	72.0
06:00	46.0	73.0
07:00	45.3	73.0
08:00	45.7	75.0
09:00	46.6	78.1
10:00	51.3	79.0
11:00	56.5	80.1
12:00	59.0	81.0
13:00	60.8	82.0
14:00	60.6	81.0
15:00	61.7	79.0
16:00	61.7	77.0
17:00	61.0	75.0
18:00	59.2	73.0
19:00	55.0	73.0
20:00	53.4	72.0
21:00	51.6	71.1
22:00	49.8	72.0
23:00	48.9	72.0
24:00	47.7	72.0

23. On the blank sheet of graph paper in Figure 1.4, plot the hourly temperatures measured for Tucson and Honolulu on 19 January 2006. (**10 points**)

24. Which city had the highest temperature on 19 January 2006? (**2 points**)

25. Which city had the highest *average* temperature? (**2 points**)

26. Which city heated up the fastest in the morning hours? (**2 points**)

While straight lines and perfect data show up in science from time to time, it is actually quite rare for *real* data to fit perfectly on top of a line. One reason for this is that all



Figure 1.4: Graph paper for plotting the hourly temperatures in Tucson and Honolulu.

measurements have *error*. So even though there might be a perfect relationship between x and y , the uncertainty of the measurements introduces small deviations from the line. In other cases, the data are *approximated* by a line. This is sometimes called a *best-fit* relationship for the data.

1.10 Does it Make Sense?

This is a question that you should be asking yourself after *every* calculation that you do in this class!

One of our primary goals this semester is to help you develop intuition about our solar system. This includes recognizing if an answer that you get “makes sense.” For example, you may be told (or you may eventually know) that Mars is 1.5 AU from Earth. You also know that the Moon is a lot closer to the Earth than Mars is. So if you are asked to calculate the

Earth-Moon distance and you get an answer of 4.5 AU, this should alarm you! That would imply that the Moon is **three times** farther away from Earth than Mars is! And you know that's not right.

Use your intuition to answer the following questions. In addition to just giving your answer, state *why* you gave the answer you did. (**5 points each**)

27. Earth's diameter is 12,756 km. Jupiter's diameter is about 11 times this amount. Which makes more sense: Jupiter's diameter being 19,084 km or 139,822 km?

28. Sound travels through air at roughly 0.331 kilometers per second. If BX 102 suddenly exploded, which would make more sense for when people in Mesilla (almost 5 km away) would hear the blast? About 14.5 seconds later, or about 6.2 minutes later?

29. Water boils at 100 °C. Without knowing anything about the planet Pluto other than the fact that is roughly 40 times farther from the Sun than the Earth is, would you expect the surface temperature of Pluto to be closer to -100° or 50°?

1.11 Putting it All Together

We have covered a lot of tools that you will need to become familiar with in order to complete the labs this semester. Now let's see how these concepts can be used to answer real questions about our solar system. *Remember, ask yourself **does this make sense?** for each answer that you get!*

30. To travel from Las Cruces to New York City by car, you would drive 3585 km. What is this distance in AU? (**10 points**)

31. The Earth is 4.5 billion years old. The dinosaurs were killed 65 million years ago due to a giant impact by a comet or asteroid that hit the Earth. If we were to compress the history of the Earth from 4.5 billion years into one 24-hour day, at what time would the dinosaurs have been killed? (**10 points**)

32. When it was launched towards Pluto, the New Horizons spacecraft was traveling at approximately 20 kilometers per second. How long did it take to reach Jupiter, which is roughly 4 AU from Earth? [Hint: see the definition of an AU in Section 1.3 of this lab.] (**7 points**)

Name: _____

Date: _____

2 Optics

2.1 Introduction

Unlike other scientists, astronomers are far away from the objects they want to examine. Therefore astronomers learn everything about an object by studying the light it emits. Since objects of astronomical interest are far away, they appear very dim and small to us. Thus astronomers must depend upon telescopes to gather more information. Lenses and mirrors are used in telescopes which are the instruments astronomers use to observe celestial objects. Therefore it is important for us to have a basic understanding of optics in order to optimize telescopes and interpret the information we receive from them.

The basic idea of optics is that mirrors or lenses can be used to change the direction which light travels. Mirrors change the direction of light by *reflecting* the light, while lenses redirect light by *refracting*, or bending the light.

The theory of optics is an important part of astronomy, but it is also very useful in other fields. Biologists use microscopes with multiple lenses to see very small objects. People in the telecommunications field use fiber optic cables to carry information at the speed of light. Many people benefit from optics by having their vision corrected with eyeglasses or contact lenses.

This lab will teach you some of the basic principles of optics which will allow you to be able to predict what mirrors and lenses will do to the light which is incident on them. At the observatory you use real telescopes, so the basic skills you learn in this lab will help you understand telescopes better.

- *Goals:* to discuss the properties of mirrors and lenses, and demonstrate them using optics; build a telescope
- *Materials:* optical bench, ray trace worksheet, meterstick

2.2 Discussion

The behavior of light depends on how it strikes the surface of an object. All angles are measured with respect to the **normal** direction. The normal direction is defined as a line which is perpendicular to the surface of the object. The angle between the normal direction and the surface of the object is 90° . Some important definitions are given below. Pay special attention to the pictures in Figure 2.1 since they relate to the reflective (mirrors) and refractive (lenses) optics which will be discussed in this lab.

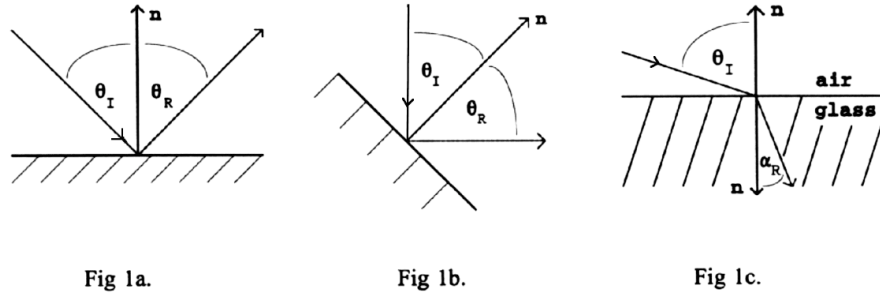

Figure 2.1: The definition of the “normal” direction \mathbf{n} , and other angles found in optics.

- \mathbf{n} = line which is always perpendicular to the surface; also called the *normal*
- θ_I = angle of *incidence*; the angle between the *incoming* light ray and the normal to the surface
- θ_R = angle of *reflection*; the angle between the *outgoing* light ray and the normal to the surface
- α_R = angle of *refraction*; the angle between the *transmitted* light ray and the normal direction

2.3 Reflective Optics: Mirrors

How do mirrors work? Let’s experiment by reflecting light off of a simple flat mirror.

As part of the equipment for this lab you have been given a device that has a large wooden protractor mounted in a stand that also has a flat mirror. Along with this set-up comes a “Laser Straight” laser alignment tool. Inside the Laser Straight is a small laser. There is a small black switch which turns the laser on and off. Keep it off, except when performing the following exercise (always be careful around lasers—they can damage your eyes if you stare into them!).

With this set-up, we can explore how light is reflected off of a flat mirror. Turn on the Laser Straight, place it on the wooden part of the apparatus outside the edge of the protractor so that the laser beam crosses across the protractor scale and intercepts the mirror. Align the laser at some angle on the protractor, making sure the laser beam passes through the *vertex* of the protractor. Note how the “incident” laser beam is reflected. Make a sketch of what you observe in the space below.

Table 2.1: Data Table

Angle of Incidence	Angle of Reflection
20°	
30°	
45°	
60°	
75°	
90°	

Now experiment using different angles of incidence by rotating the Laser Straight around the edge of the protractor, always insuring the laser hits the mirror exactly at the vertex of the protractor. Note that an angle of incidence of 90° corresponds to the “normal” defined above (see Fig. 2.1a).

1. Fill in Table 2.1 with the data for angle of incidence vs. angle of reflection. (**3 pts**)
2. What do you conclude about how light is reflected from a mirror? (**2 pts**)

The law governing the behavior of light when it strikes a mirror is known as the **Law of Reflection**:

angle of incidence = angle of reflection

$$\theta_I = \theta_R$$

3. OK, now what happens if you make the mirror curved? First let's consider a *concave* mirror, one which is curved *away* from the light source. Try to think about the curved mirror as being made up of lots of small subsections of flat mirrors, and make a prediction for what you will see if you put a curved mirror in the light path. You might try to make a drawing in the space below:

At the front of the classroom is in fact just such a device: A curved wooden base to which are glued a large number of flat mirrors, along with a metal stand that has three lasers mounted in it, and the “disco5000” smoke machine. Have your TA turn on the lasers, align them onto the multi-mirror apparatus, and spew some smoke!

4. Was your prediction correct?

Also at the front of the room are two large curved mirrors. There are two types of curved mirrors, “convex” and “concave”. In a convex mirror, the mirror is curved outwards, in a concave mirror, the mirror is curved inwards (“caved” in). Light that is reflected from these two types of mirrors behaves in different ways. In this subsection of the lab, you will investigate how light behaves when encountering a curved mirror.

5. Have your TA place the laser apparatus in front of the convex mirror, and spew some more smoke. **BE CAREFUL NOT TO LET THE LASER LIGHT HIT YOUR EYE.** What happens to the laser beams when they are reflected off of the convex mirror? Make a drawing of how the light is reflected (using the attached work sheet, the diagram labeled “Convex Mirror” in Figure 2.2). (**5 pts**)
6. Now have your TA replace the convex mirror with the concave mirror. Now what happens to the laser beams? Draw a diagram of what happens (using the same worksheet, in the space labeled “Concave Mirror”). (**5 pts**)
7. Note that there are three laser beams. Using a piece of paper, your hand, or some other small opaque item, block out the top laser beam on the stand. Which of the reflected beams disappeared? What happens to the images of the laser beams upon reflection? Draw this result (**5 pts**):

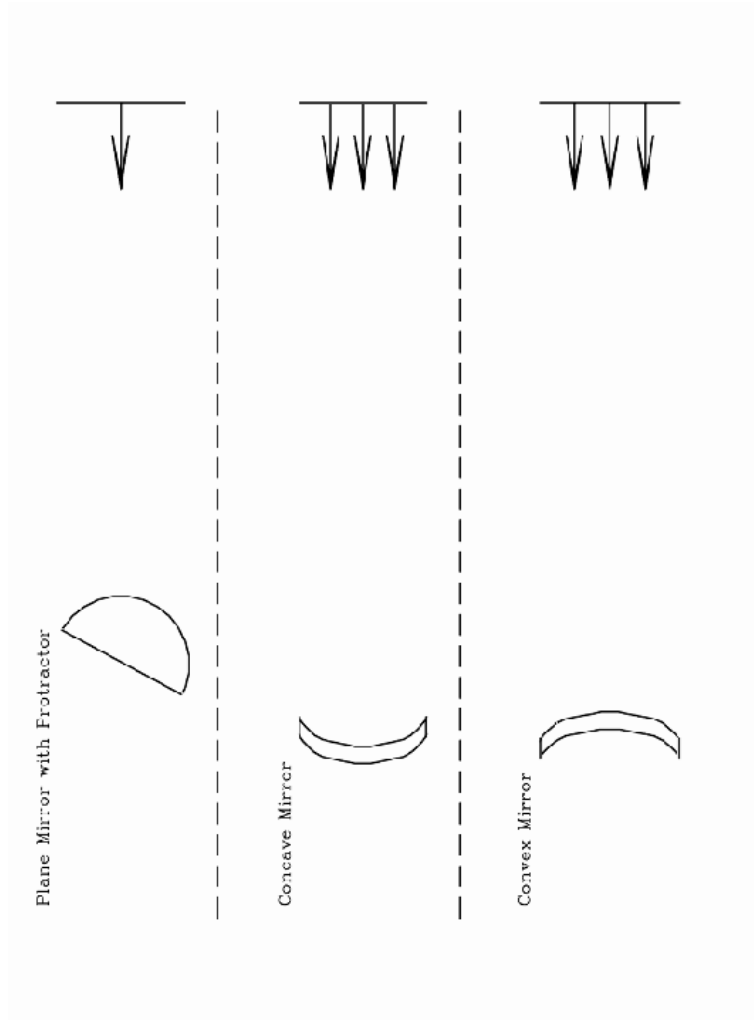

Figure 2.2: The worksheet needed in subsection 3

8. The point where the converging laser beams cross is called the “focus”. From these experiments, we can draw the conclusion that *concave mirrors focus light, convex mirrors diverge light*. Both of the mirrors are 61 cm in diameter. Using a meter stick, how far from the mirror is the convergent point of the reflected light (“where is the best focus achieved”)? (**3 pts**)

This distance is called the “focal length”. For concave mirrors the focal length is one half of the “radius of curvature” of the mirror. If you could imagine a spherical mirror, cut the sphere in half. Now you have a hemispherical mirror. The radius of the hemisphere is the same as the radius of the sphere. Now, imagine cutting a small cap off of the hemisphere, now you have a concave mirror, but it is a piece of a sphere that has the same radius as before!

9. What is the radius of curvature of the big concave mirror? (**1 pt**)
10. Ok, with the lasers off, look into the concave mirror, is your face larger or smaller? Does a concave mirror appear to magnify, or demagnify your image. How about the convex mirror, does it appear to magnify, or demagnify? (**1 pt**):

2.4 Refractive Optics: Lenses

How about lenses? Do they work in a similar way?

For this subsection of the lab, we will be using an “optical bench” that has a light source on one end, and a projection (imaging) screen on the other end. To start with, there will be three lenses attached mounted on the optical bench. Loosen the (horizontal) thumbscrews and remove the three lenses from the optical bench. Two of the lenses have the same diameter, and one lens is larger. Holding one of the lenses by the steel shaft, examine whether this lens can be used as a “magnifying glass”, that is when you look through it, do objects appear bigger, or smaller? You will find that two of the lenses are “positive” lenses in that they magnify objects, and one is a “negative” lens that acts to “de-magnify” objects. Note how easy it is to decide which lenses are positive and which one is the negative lens.

Now we are going to attempt to measure the “focal lengths” of these lenses. First, remount the smaller positive lens back on the optical bench. Turn on the light by simply connecting the light source to the battery and turning on the switch. Take the smaller *positive* lens move it to the middle of the optical bench (tightening or loosening the vertical clamping screw to allow you to slide it back and forth). At the one end of the optical bench mount the white plastic viewing screen. It is best to mount this at a convenient measurement spot—let’s choose to align the plastic screen so that it is right at the 10 cm position on the meter stick. Now slowly move the lens closer to the screen. As you do so, you should see a

circle of light that decreases in size until you reach “focus” (for this to work, however, your light source and lens have to be at the same *height* above the meter stick!).

11. Measure the distance between the lens and the plastic screen. Write down this number, we will call it “*a*”.

The distance “*a*” = cm (**1 pt**)

12. Now measure the distance between the lens and the front end of the light source.

Write down this number, we will call it “*b*”:

The distance “*b*” = cm (**1 pt**)

To determine the focal length of a lens (“*F*”), there is a formula called “the lens maker’s formula”:

$$\frac{1}{F} = \frac{1}{a} + \frac{1}{b} \tag{1}$$

13. Calculate the focal length of the small positive lens (**2 pts**): *F* = cm

14. Now replace the positive lens with the small *negative* lens. Repeat the process. Can you find a focus with this lens? What appears to be happening? (**4 pts**)

15. How does the behavior of these two lenses compare with the behavior of mirrors? Draw how light behaves when encountering the two types of lenses using Figure 2.3. Note some similarities and differences between what you have drawn in Fig. 2.2, and what you drew in Fig. 2.3 and write them in the space below. (**5 pts**)

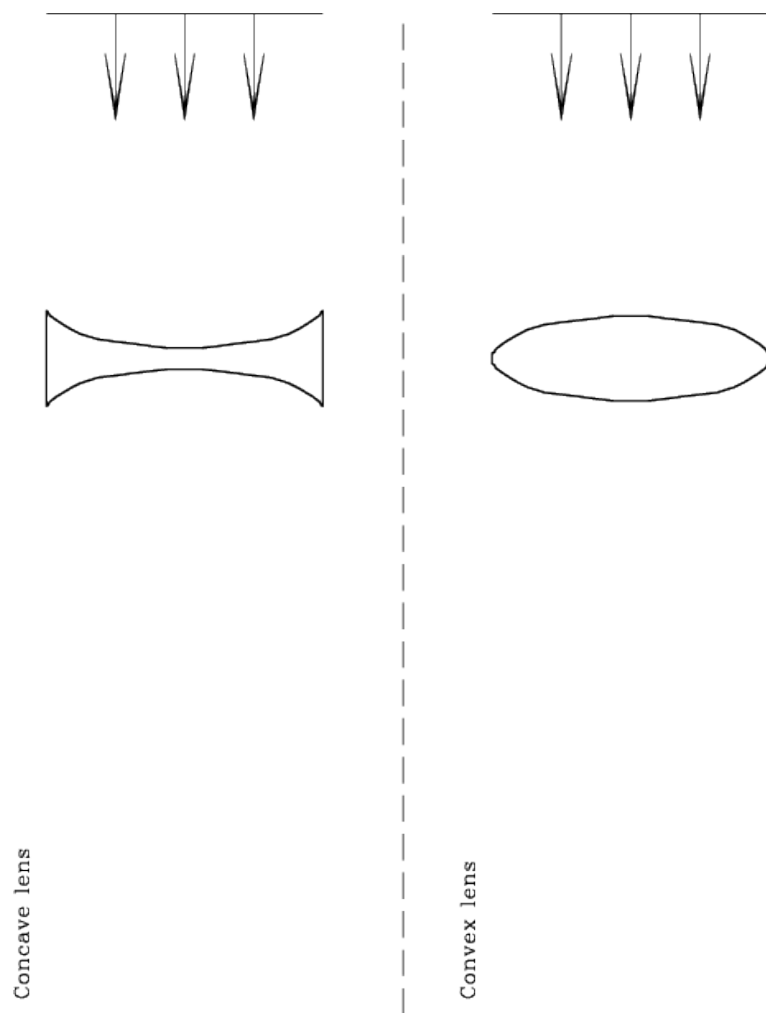

Figure 2.3: The worksheet needed in subsection 4. The positive lenses used in this lab are “double convex” lenses, while the negative lens is a “double concave” lens.

Ok, now let's go back and mount the larger lens on the optical bench. This lens has a very long focal length. Remove the light source from the optical bench. Now mount the big lens exactly 80 cm from the white screen. Holding the light source "out in space", move it back and forth until you can get the best focus (Note that this focus will not be a point, but will be a focused image of the filament in the light bulb and show-up as a small, bright line segment. This is a much higher power lens, so the image is not squished down like occurred with the smaller positive lens). Using the wooden meter stick, have your lab partners measure the distance between the light source and the lens. This is hard to do, but you should get a number that is close to 80 cm.

16. Assuming that $a = b = 80$ cm, use the lens maker's formula to calculate F :

The focal length of the large lens is $F =$ _____ cm (**2 pts**)

2.5 Making a Telescope

As you have learned in class, Galileo is given credit as the first person to point a telescope at objects in the night sky. You are now going to make a telescope just like that used by Galileo. Remove the white screen (and light source) from the optical bench and mount (and lock) the large positive lens at the 10 cm mark on the yardstick scale. Now mount the small *negative* lens about 40 cm away from the big lens. Looking at the "eyechart" mounted in the lab room (maybe go to the back of the room if you are up front—you want to be as far from the eyechart as possible), focus the telescope by moving the little lens backwards or forwards. Once you achieve focus, let your lab partners look through the telescope too. Given that everyone's eyes are different, they may need to re-focus the little lens.

17. Write down the distance "N" between the two lenses:

The distance between the two lenses is $N =$ _____ cm (**2 pts**)

18. Describe what you see when you look through the telescope: What does the image look like? Is it distorted? Are there strange colors? What is the smallest set of letters you can read? Is the image right side up? Any other interesting observations? (**5 pts**):

This is exactly the kind of telescope that Galileo used. Shortly after Galileo's observations became famous, Johannes Kepler built his own telescopes, and described how they worked. Kepler suggested that you could make a better telescope using two *positive* lenses. Let's do that. Remove the small negative lens and replace it with the small positive lens. Like before, focus your telescope on the eyechart, and let everyone in your group do the same. Write down the distance "P" between the two lenses after achieving best focus:

19. The distance between the two lenses is $P =$ _____ cm (**2 pts**)
20. Describe what you see: What does the image look like? Is it distorted? Are there strange colors? What is the smallest set of letters you can read? Is the image right side up? Any other interesting observations? (**5 pts**):
21. Compare the two telescopes. Which is better? What makes it better? Note that Kepler's version of the telescope did not become popular until many years later. Why do you think that is? (**5 pts**):

2.5.1 The Magnifying and Light Collecting Power of a Telescope

Telescopes do two important things: they collect light, and magnify objects. Astronomical objects are very far away, and thus you must magnify the objects to actually see any detail. Telescopes also collect light, allowing you to see fainter objects than can be seen by your eye. It is easy to envision this latter function as two different size buckets sitting out in the rain. The bigger diameter bucket will collect more water than the smaller bucket. In fact, the amount of water collected goes as the area of the top of the bucket. If we have circular buckets, then given that the area of a circle is πR^2 , a bucket that is twice the radius, has four times the area, and thus collects four times the rain. The same relationship is at work for your eye and a telescope. The radius of a typical human pupil is 4 mm, while the big lens you have been using has a radius of 20 mm. Thus, the telescopes that you built collect 25 times as much light as your eyes.

Determining the magnification of a telescope is also very simple:

$$M = \frac{F}{f} \quad (2)$$

Where “M” is the magnification, “F” is the focal length of the “objective” lens (the bigger of the two lenses), and “f” is the focal length of the “eyepiece” (the smaller of the two lenses). You have calculated both “F” and “f” in the preceding for the two positive lenses, and thus can calculate the *magnification of the “Kepler” telescope*:

22. The magnification of the Kepler telescope is $M =$ _____ times. (1 pt)

Ok, how about the magnification of the Galileo telescope? The magnification for the Galileo telescope is calculated the same way:

$$M = \frac{F}{f} \quad (3)$$

But remember, we could not measure a focal length (f) for the negative lens. How can this be done? With specialized optical equipment it is rather easy to measure the focal length of a negative lens. But since we do not have that equipment, we have to use another technique. In the following two figures we show a “ray diagram” for both the Kepler and Galileo telescopes.

Earlier, we had you make various measurements of the lenses, and measure separations of the lenses in both telescopes once they were focused. If you look at Figure 2.4 and

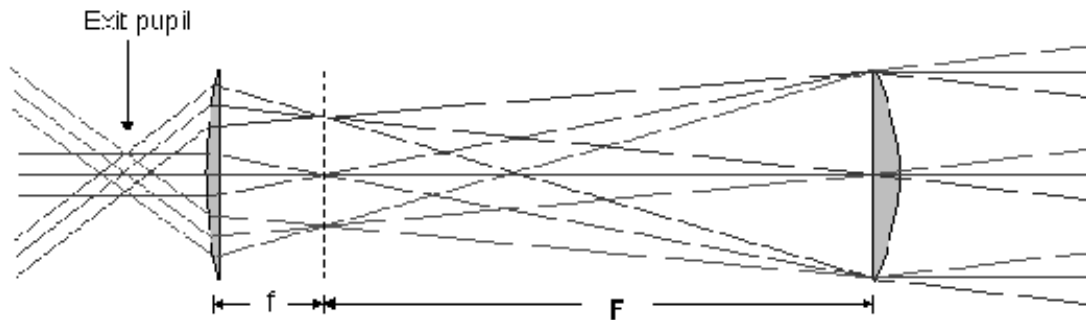

Figure 2.4: The ray diagram for Kepler's telescope.

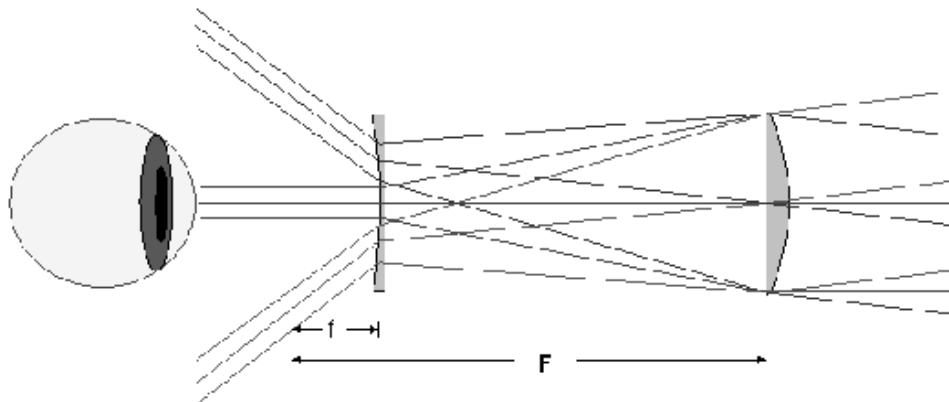

Figure 2.5: The ray diagram for Galileo's telescope.

Figure 2.5, you will see that there is a large “F”. This is the focal length of the large, positive lens (the “objective”). In Kepler's telescope, when it is focused, you see that the separation between the two lenses is the sum of the focal lengths of the two lenses. We called this distance “P”, above. You should confirm that the “P” you measured above is in fact equal (or fairly close) to the sum of the focal lengths of the two positive lenses: $P = f + F$ (where little “f” is the focal length of the smaller positive lens).

Ok, now look at Figure 2.5. Note that when this telescope is focused, the separation between the two lenses in the Galileo telescope is $N = F - f$ (where F and f have the same definition as before).

23. Find “f” for the Galileo telescope that you built, and determine the magnification of this telescope (**3 pts**):

24. Compare the magnification of your Galileo telescope to that you calculated for the Kepler telescope (**2 pts**):

What do you think of the quality of images that these simple telescopes produce? Note how hard it is to point these telescopes. It was hard work for Galileo, and the observers that followed him, to unravel what they were seeing with these telescopes. You should also know that the lenses you have used in this class, even though they are not very expensive, are far superior to those that could be made in the 17th century. Thus, the simple telescopes you have constructed today are much better than what Galileo used!

2.6 Summary (35 points)

Please summarize the important concepts of this lab.

- Describe the properties of the different types of lenses *and* mirrors discussed in this lab
- What are some of the differences between mirrors and lenses?
- Why is the study of optics important in astronomy?

Use complete sentences, and proofread your lab before handing it in.

2.7 Possible Quiz Questions

- 1) What is a “normal”?
- 2) What is a concave mirror?
- 3) What is a convex lens?
- 4) Why do astronomers need to use telescopes?

2.8 Extra Credit (ask your TA for permission before attempting, 5 points)

Astronomers constantly are striving for larger and larger optics so that they can collect more light, and see fainter objects. Galileo’s first telescope had a simple lens that was 1” in diameter. The largest telescopes on Earth are the Keck 10 m telescopes (10 m = 400 inches!). Just about all telescopes use mirrors. The reason is that lenses have to be supported from their edges, while mirrors can be supported from behind. But, eventually, a single mirror gets too big to construct. For this extra credit exercise look up what kind of mirrors the 8 m Gemini telescopes have (at <http://www.gemini.edu>) versus the mirror system used by the Keck telescopes (http://keckobservatory.org/about/the_observatory). Try to find out how they were made using links from those sites. Write-up a description of the mirrors used in these two telescopes. Do you think the next generation of 30 or 100 m telescopes will be built, like Gemini, or Keck? Why?

Name: _____

Date: _____

3 The Power of Light: Understanding Spectroscopy

3.1 Introduction

For most celestial objects, light is the astronomer's only subject for study. Light from celestial objects is packed with amazingly large amounts of information. Studying the distribution of brightness for each wavelength (color) which makes up the light provides the temperature of a source. A simple example of this comes from flame color comparison. Think of the color of a flame from a candle (yellow) and a flame from a chemistry class Bunsen burner (blue). Which is hotter? The flame from the Bunsen burner is hotter. By observing which color is dominant in the flame, we can determine which flame is hotter or cooler. The same is true for stars; by observing the color of stars, we can determine which stars are hot and which stars are cool. If we know the temperature of a star, and how far away it is (see the "Measuring Distances Using Parallax" lab), we can determine how big a star is.

We can also use a device, called a spectroscope, to break-up the light from an object into smaller segments and explore the chemical composition of the source of light. For example, if you light a match, you know that the predominant color of the light from the match is yellow. This is partly due to the temperature of the match flame, but it is also due to very strong *emission lines* from sodium. When the sodium atoms are excited (heated in the flame) they emit yellow light.

In this lab, you will learn how astronomers can use the light from celestial objects to discover their nature. You will see just how much information can be packed into light! The close-up study of light is called *spectroscopy*.

This lab is split into three main parts:

- Experimentation with actual blackbody light sources to learn about the qualitative behavior of blackbody radiation.
- Computer simulations of the quantitative behavior of blackbody radiation.
- Experimentation with emission line sources to show you how the spectra of each element is unique, just like the fingerprints of human beings.

Thus there are three main components to this lab, and they can be performed in any order. So one third of the groups can work on the computers, while the other groups work with the spectrographs and various light sources.

- *Goals:* to discuss the properties of blackbody radiation, filters, and see the relationship between temperature and color by observing light bulbs and the spectra of elements by

looking at emission line sources through a spectrograph. Using a computer to simulate blackbody radiation

- *Materials:* spectrograph, adjustable light source, gas tubes and power source, computers, calculators

3.2 Blackbody Radiation

Blackbody radiation (light) is produced by any hot, dense object. By “hot” we mean any object with a temperature above absolute zero. All things in the Universe emit radiation, since all things in the Universe have temperatures above absolute zero. Astronomers *idealize* a perfect absorber and perfect emitter of radiation and call it a “blackbody”. This does not mean it is black in color, simply that it absorbs and emits light at all wavelengths, so no light is reflected. A blackbody is an object which is a perfect absorber (absorbs at all wavelengths) and a perfect emitter (emits at all wavelengths) and does not reflect any light from its surface. Astronomical objects are not perfect blackbodies, but some, in particular, stars, are fairly well approximated by blackbodies.

The light emitted by a blackbody object is called blackbody radiation. This radiation is characterized simply by the *temperature* of the blackbody object. Thus, if we can study the blackbody radiation from an object, we can determine the temperature of the object.

To study light, astronomers often split the light up into a spectrum. A spectrum shows the distribution of brightness at many different wavelengths. Thus, a spectrum can be shown using a graph of brightness vs. wavelength. A simple example of this is if you were to look at a rainbow and record how bright each of the separate colors were. Figure 3.1 shows what the brightness of the colors in a hot flame or hot star might look like. At each separate color, a brightness is measured. By fitting a curve to the data points, and finding the peak in the curve, we can determine the temperature of the blackbody source.

3.3 Absorption and Emission Lines

One question which you may have considered is: how do astronomers know what elements and molecules make up astronomical objects? How do they know that the Universe is made up mostly of hydrogen with a little bit of helium and a tiny bit of all the other elements we have discovered on Earth? How do astronomers know the chemical make up of the planets in our Solar System? They do this by examining the absorption or emission lines in the spectra of astronomical sources. [Note that the plural of *spectrum* is *spectra*.]

3.3.1 The Bohr Model of the Atom

In the early part of the last century, a group of physicists developed the *Quantum Theory of the Atom*. Among these scientists was a Danish physicist named Niels Bohr. His model

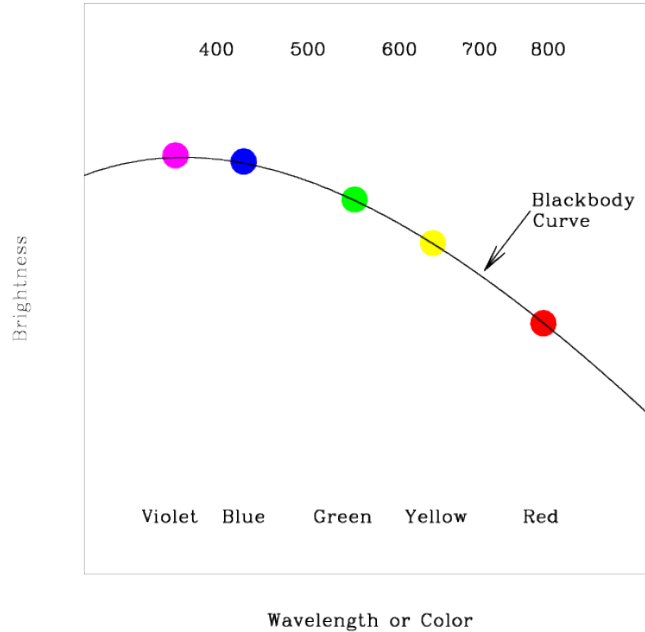

Figure 3.1: Astronomers measure the amount of light at a number of different wavelengths (or colors) to determine the temperature of a blackbody source. Every blackbody has the same shape, but the peak moves to the violet/blue for hot sources, and to the red for cool sources. Thus we can determine the temperature of a blackbody source by figuring out where the most light is emitted.

of the atom, shown in the figure below, is the easiest to understand. In the Bohr model, we have a nucleus at the center of the atom, which is really much, much smaller relative to the electron orbits than is illustrated in our figure. Almost all of the atom's mass is located in the nucleus. For Hydrogen, the simplest element known, the nucleus consists of just one proton. A proton has an atomic mass unit of 1 and a positive electric charge. In Helium, the nucleus has two protons and two other particles called neutrons which do not have any charge but do have mass. An electron cloud surrounds the nucleus. For Hydrogen there is only one electron. For Helium there are two electrons and in a larger atom like Oxygen, there are 8. The electron has about $\frac{1}{2000}$ the mass of the proton but an equal and opposite electric charge. So protons have positive charge and electrons have negative charge. Because of this, the electron is attracted to the nucleus and will thus stay as close to the nucleus as possible.

In the Bohr model, Figure 3.2, the electron is allowed to exist only at *certain* distances from the nucleus. This also means the electron is allowed to have *only certain orbital energies*. Often the terms *orbits*, *levels*, and *energies* are used interchangeably so try not to get confused. They all mean the same thing and all refer to the electrons in the Bohr model of the atom.

Now that our model is set up let's look at some situations of interest. When scientists

Hydrogen Atom

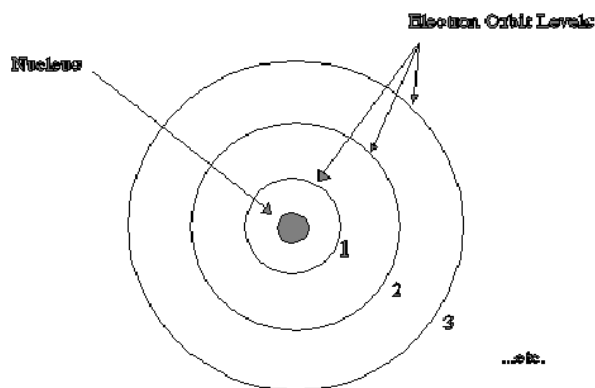

Bohr Model

Figure 3.2: In the Bohr model, the negatively charged electrons can only orbit the positively charged nucleus in specific, “quantized”, orbits.

studied simple atoms in their normal, or average state, they found that the electron was found in the lowest level. They named this level the ground level. When an atom is exposed to conditions other than average, say for example, putting it in a very strong electric field, or by increasing its temperature, the electron will jump from inner levels toward outer levels. Once the abnormal conditions are taken away, the electron jumps downward towards the ground level and emits some light as it does so. The interesting thing about this light is that it comes out at only *particular* wavelengths. It does not come out in a continuous spectrum, but at solitary wavelengths. What has happened here?

After much study, the physicists found out that the atom had taken-in energy from the collision or from the surrounding environment and that as it jumps downward in levels, it re-emits the energy as light. The light is a particular color because the electron really is allowed only to be in certain discrete levels or orbits. It cannot be halfway in between two energy levels. This is not the same situation for large scale objects like ourselves. Picture a person in an elevator moving up and down between floors in a building. The person can use the emergency stop button to stop in between any floor if they want to. An electron cannot. It can only exist in certain energy levels around a nucleus.

Now, since each element has a different number of protons and neutrons in its nucleus and a different number of electrons, you may think that studying “electron gymnastics” would get very complicated. Actually, nature has been kind to us because at any one time, only a single electron in a given atom jumps around. This means that each element, when it is excited, gives off certain colors or wavelengths. This allows scientists to develop a color *fingerprint* for each element. This even works for molecules. These fingerprints are sometimes referred to as spectral lines. The light coming from these atoms does not take the

shape of lines. Rather, each atom produces its own set of distinct colors. Scientists then use lenses and slits to produce an image in the shape of a line so that they can measure the exact wavelength accurately. This is why spectral lines get their name, because they are generally studied in a linear shape, but they are actually just different wavelengths of light.

3.3.2 Kirchoff's Laws

Continuous spectra are the same as blackbody spectra, and now you know about spectral lines. But there are two types of spectral lines: *absorption* lines and *emission* lines. Emission lines occur when the electron is moving down to a lower level, and emits some light in the process. An electron can also move up to a higher level by absorbing the right wavelength of light. If the atom is exposed to a continuous spectrum, it will absorb only the right wavelength of light to move the electron up. Think about how that would affect the continuous spectrum. One wavelength of light would be absorbed, but nothing would happen to the other colors. If you looked at the source of the continuous spectrum (light bulb, core of a star) through a spectrograph, it would have the familiar Blackbody spectrum, with a dark line where the light had been absorbed. This is an absorption line.

The absorption process is basically the reverse of the emission process. The electron must acquire energy (by absorbing some light) to move to a higher level, and it must get rid of energy (by emitting some light) to move to a lower level. If you're having a hard time keeping all this straight, don't worry. Gustav Kirchoff made it simple in 1860, when he came up with three laws describing the processes behind the three types of spectra. The laws are usually stated as follows:

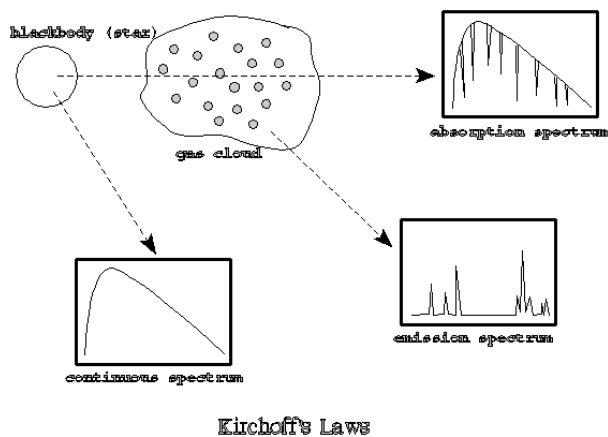

- **I.** A dense object will produce a continuous spectrum when heated.

- **II.** A low-density, gas that is excited (meaning that the atoms have electrons in higher levels than normal) will produce an emission-line spectrum.

- **III.** If a source emitting a continuous spectrum is observed through a cooler, low-density gas, an absorption-line spectrum will result.

A blackbody produces a continuous spectrum. This is in agreement with Kirchoff's first law. When the light from this blackbody passes through a cloud of cooler gas, certain wavelengths are absorbed by the atoms in that gas. This produces an absorption spectrum according to Kirchoff's third law. However, if you observe the cloud of gas from a different angle, so you cannot see the blackbody, you will see the light emitted from the atoms when the excited electrons move to lower levels. This is the emission spectrum described by Kirchoff's second law.

Kirchoff's laws describe the conditions that produce each type of spectrum, and they are a helpful way to remember them, but a real understanding of what is happening comes from the Bohr model.

In the second half of this lab you will be observing the spectral lines produced by several different elements when their gaseous forms are heated. The goal of this subsection of the lab is to observe these emission lines and to understand their formation process.

3.4 Creating a Spectrum

Light which has been split up to create a spectrum is called dispersed light. By dispersing light, one can see how pure white light is really made up of all possible colors. If we disperse light from astronomical sources, we can learn a lot about that object. To split up the light so you can see the spectrum, one has to have some kind of tool which disperses the light. In the case of the rainbow mentioned above, the dispersing element is actually the raindrops which are in the sky. Another common dispersing element is a prism.

We will be using an optical element called a *diffraction grating* to split a source of white light into its component colors. A diffraction grating is a bunch of really, really, small rectangular openings called slits packed close together on a single sheet of material (usually plastic or glass). They are usually made by first etching a piece of glass with a diamond and a computer driven etching machine and then taking either casts of the original or a picture of the original.

The diffraction grating we will be using is located at the optical entrance of an instrument called a *spectroscope*. The image screen inside the spectroscope is where the dispersed light ends up. Instead of having all the colors land on the same spot, they are dispersed across the screen when the light is split up into its component wavelengths. The resultant dispersed light image is called a spectrum.

3.5 Observing Blackbody Sources with the Spectrograph

In part one of this lab, we will study a common blackbody in everyday use: a simple white light bulb. Your Lab TA will show you a regular light bulb at two different brightnesses (which correspond to two different temperatures). The light bulb emits at all wavelengths, even ones that we can't see with our human eyes. You will also use a spectroscope to observe emission line sources.

1. First, get a spectroscope from your lab instructor. Study Figure 3.3 figure out which way the entrance slit should line up with the light source. **DO NOT TOUCH THE ENTRANCE SLIT OR DIFFRACTION GRATING!** Touching the plastic ends degrades the effectiveness and quality of the spectroscope.

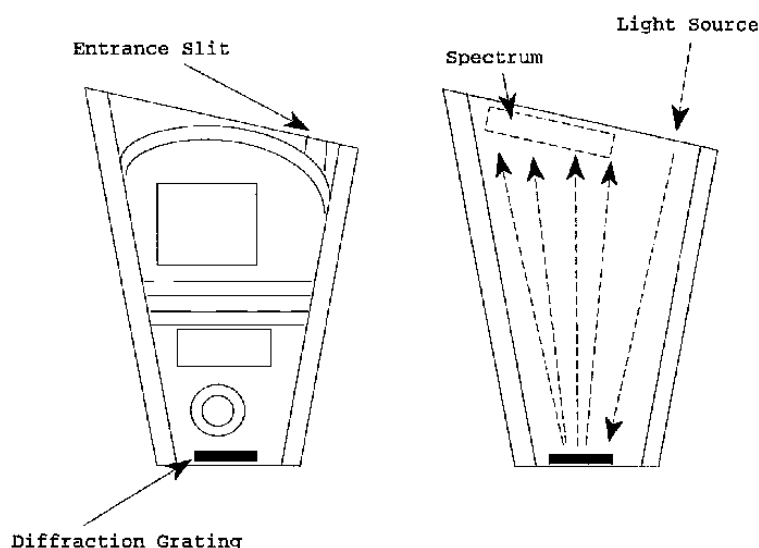

Figure 3.3:

2. Observe the light source at the brighter (hotter) setting.
3. Do you see light at all different wavelengths/colors or only a few discrete wavelengths? **(2 points)**
4. Of all of the colors which you see in the spectrographs, which color appears the brightest?**(3 points)**
5. Now let us observe the light source at a cooler setting. Do you see light at all different wavelengths/colors or only a few discrete wavelengths? Of all of the colors which you see in the spectrographs, which color appears the brightest? **(3 points)**
6. Describe the changes between the two light bulb observations. What happened to the spectrum as the brightness and temperature of the light bulb increased? Specifically, what happened to the relative amount of light at different wavelengths?**(5 points)**

7. Betelgeuse is a Red Giant Star found in the constellation Orion. Sirius, the brightest star in the sky, is much hotter and brighter than Betelgeuse. Describe how you might expect the colors of these two stars to differ. (4 points)

3.6 Quantitative Behavior of Blackbody Radiation

This subsection, which your TA may make optional (or done as one big group), should be done outside of class on a computer with network access, we will investigate how changing the temperature of a source changes the characteristics of the radiation which is emitted by the source. We will see how the measurement of the *color* of an object can be used to determine the object's temperature. We will also see how changing the temperature of a source also affects the source's *brightness*.

To do this, we will use an online computer program which simulates the spectrum for objects at a given temperature. This program is located here:

<http://astro.unl.edu/naap/blackbody/animations/blackbody.html>

The program just produces a graph of wavelength on the x-axis vs. brightness on the y-axis; you are looking at the relative brightness of this source at different wavelengths.

The program is simple to use. There is a sliding bar on the bottom of the “applet” that allows you to set the temperature of the star. Play around with it a bit to get the idea. Be aware that the y-axis scale of the plot will change to make sure that none of the spectrum goes off the top of the plot; thus if you are looking at objects of different temperature, the y-scale can be different.

Note that the temperature of the objects are measured in units called degrees Kelvin (K). These are very similar to degrees Centigrade/Celsius (C); the only difference is that: $K = C + 273$. So if the outdoor temperature is about 20 C (68 Fahrenheit), then it is 293 K. Temperatures of stars are measured in *thousands* of degrees Kelvin; they are much hotter than it is on Earth!

1. Set the object to a temperature of around 6000 degrees, which is the temperature of the Sun. Note the wavelength, and the color of the spectrum at the peak of the blackbody curve.
2. Now set the temperature to 3000 K, much cooler than the Sun. How do the spectra differ? Consider both the *relative* amount of light at different wavelengths as well as the overall *brightness*. Now set the temperature to 12,000 K, hotter than Sun. How do the spectra differ? (5 points)
3. You can see that each blackbody spectrum has a wavelength where the emission is the brightest (the “top” of the curve). Note that this wavelength changes as the temperature is changed. Fill in the following small table of the wavelength (in “nanometers”)

of the peak of the curve for objects of several different temperatures. You should read the wavelengths at the peak of the curve by looking at the x-axis value of the peak. (5 points)

Temperature	Peak Wavelength
3000	
6000	
12000	
24000	

- Can you see a pattern from your table? Describe how the peak wavelength changes as you increase the temperature. (3 points)
- The peak wavelength and temperature are related by the equation:

$$\lambda_{\max} = \frac{2.898 \times 10^6}{T} \quad (4)$$

where λ_{\max} is the peak wavelength (in nanometers) and T is the temperature (in Kelvin). Where would the peak wavelength be for objects on Earth, at a temperature of about 300 degrees K? (2 points)

3.7 Spectral Lines Experiment

3.7.1 Spark Tubes

In space, atoms in a gas can get excited when light from a continuous source heats the gas. We cannot do this easily because it requires extreme temperatures, but we do have special equipment which allows us to excite the atoms in a gas in another way. When two atoms collide they can exchange kinetic energy (energy of motion) and one of the atoms can become excited. This same process can occur if an atom collides with a high speed electron. We can generate high speed electrons simply - it's called electricity! Thus we can excite the atoms in a gas by running electricity through the gas.

The instrument we will be using is called a spark tube. It is very similar to the equipment used to make neon signs. Each tube is filled with gas of a particular element. The tube is placed in a circuit and electricity is run through the circuit. When the electrons pass through the gas they collide with the atoms causing them to become excited. So the electrons in the atoms jump to higher levels. When these excited electrons cascade back down to the lower levels, they emit light which we can record as a spectrum.

3.7.2 Emission-line Spectra Experiment

For the third, and final subsection of this lab you will be using the spectrographs to look at the spark tubes that are emission line sources.

- The TA will first show you the emission from hot Hydrogen gas. Notice how simple this spectrum is. On the attached graphs, make a drawing of the lines you see in the spectrum of hydrogen. Be sure to label the graph so you remember which element the spectrum corresponds to. **(4 points)**
- Next the TA will show you Mercury. Notice that this spectrum is more complicated. Draw its spectrum on the attached sheet.**(4 points)**
- Next the TA will show you Neon. Draw and label this spectrum on your sheet as well.**(4 points)**

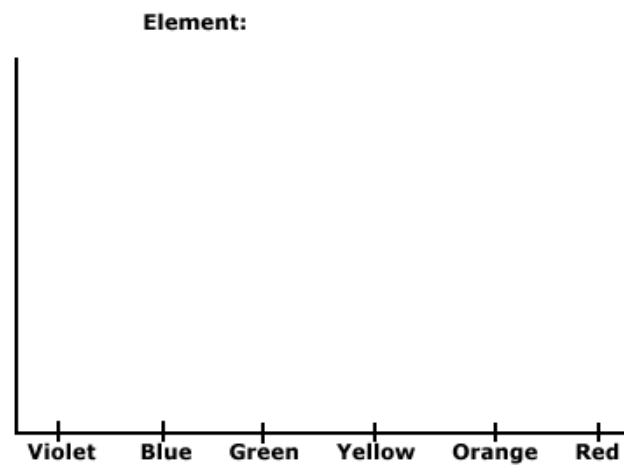
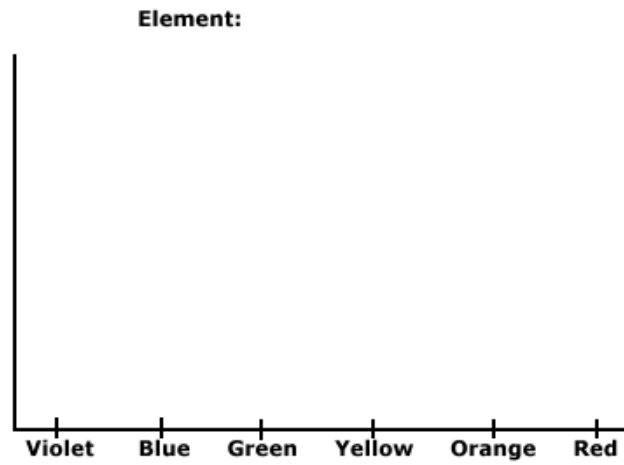
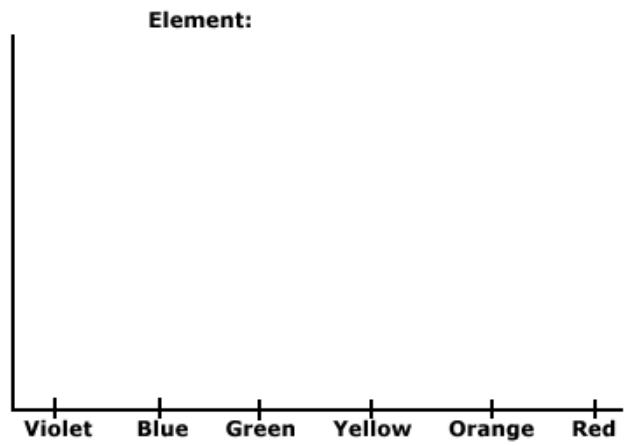

Figure 3.4: Draw your Hydrogen, Mercury and Neon spectra here.

3.7.3 The Unknown Element

Now your TA will show you one more element, but won't tell you which one. This time you will be using a higher quality spectroscope (the large gray instrument) to try to identify which element it is by comparing the wavelengths of the spectral lines with those in a data table. The gray, table-mounted spectrograph is identical in nature to the handheld spectrographs, except it is heavier, and has a more stable wavelength calibration. When you look through the gray spectroscope you will see that there is a number scale at the bottom of the spectrum. These are the wavelengths of the light in "nanometers" ($1 \text{ nm} = 10^{-9} \text{ meter}$). Look through this spectrograph at the unknown element and write down the wavelengths of the spectral lines that you can see in the table below, and note their color.

Table 3.1: Unknown Emission Line Source

Observed Wavelength (nm)	Color of Line

Now, compare the wavelengths of the lines in your data table to each of the three elements listed below. In this next table we list the wavelengths (in nanometers) of the brightest emission lines for hydrogen, helium and argon. Note that most humans cannot see light with a wavelength shorter than 400 nm or with a wavelength longer than 700 nm.

Table 3.2: Emission Line Wavelengths

Hydrogen	Helium	Argon
656.3	728.1	714.7
486.1	667.8	687.1
434.0	587.5	675.2
410.2	501.5	560.6
397.0	492.1	557.2
388.9	471.3	549.5

Which element is the unknown element? _____ (5 points)

3.8 Questions

1. Describe in detail why the emission or absorption from a particular electron would produce lines only at specific wavelengths rather than at all wavelengths like a blackbody. (Use the Bohr model to help you answer this question.) **(5 points)**
2. What causes a spectrum to have more lines than another spectrum (for example, Helium has more lines than Hydrogen)? **(4 points)**
3. Referring to Fig. 3.5, does the electron transition in the atom labeled “A” cause the emission of light, or require the absorption of light? **(2 points)**
4. Referring to Fig. 3.5, does the electron transition in the atom labeled “B” cause the emission of light, or require the absorption of light? **(2 points)**
5. Comparing the atom labeled “C” to the atom labeled “D”, which transition (that occurring in C, or D) releases the largest amount of energy? **(3 points)**

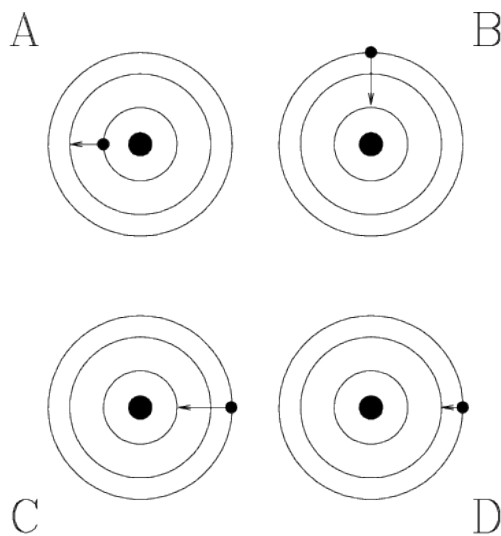

Figure 3.5: Electron transitions in an atom (the electrons are the small dots, the nucleus the large black dots, and the circles are possible orbits).

3.9 Summary (35 points)

Summarize the important ideas covered in this lab. Some questions to answer are:

- What information you can learn about a celestial object just by measuring the peak of its blackbody spectrum?
- What does a blackbody spectrum look like?
- How does the peak wavelength change as the temperature of a blackbody changes?
- How can you *quantitatively* measure the color of an object?
- Do the color of items you see around you on Earth (e.g. a red and blue shirt) tell you something about the temperature of the object? Why or why not?
- What information can you learn about an astronomical object from its spectrum?
- Explain how you would get this information from a spectrum.

Use complete sentences, and proofread your summary before handing in the lab.

3.10 Possible Quiz Questions

1. What is meant by the term “blackbody”?
2. What type of sources emit a blackbody spectrum?
3. How is an emission line spectrum produced?
4. How is an absorption line spectrum produced?
5. What type of instrument is used to produce a spectrum?

3.11 Extra Credit (ask your TA for permission before attempting, 5 points)

Research how astronomers use the spectra of binary stars to determine their masses. Write a one page paper describing this technique, including a figure detailing what is happening.

Name: _____

Date: _____

4 Measuring Distances Using Parallax

4.1 Introduction

How do astronomers know how far away a star or galaxy is? Determining the distances to the objects they study is one of the the most difficult tasks facing astronomers. Since astronomers cannot simply take out a ruler and measure the distance to any object, they have to use other methods. Inside the solar system, astronomers can simply bounce a radar signal off of a planet, asteroid or comet to directly measure the distance to that object (since radar is an electromagnetic wave, it travels at the speed of light, so you know how fast the signal travels—you just have to count how long it takes to return and you can measure the object’s distance). But, as you will find out in your lecture sessions, some stars are hundreds, thousands or even tens of thousands of “light years” away. A light year is how far light travels in a single year (about 9.5 trillion kilometers). To bounce a radar signal off of a star that is 100 light years away would require you to wait 200 years to get a signal back (remember the signal has to go out, bounce off the target, and come back). Obviously, radar is not a feasible method for determining how far away stars are.

In fact, there is one, and only one direct method to measure the distance to a star: “parallax”. Parallax is the angle that something appears to move when the observer looking at that object changes their position. By observing the size of this angle and knowing how far the observer has moved, one can determine the distance to the object. Today you will experiment with parallax, and appreciate the small angles that astronomers must measure to determine the distances to stars.

To introduce you to parallax, perform the following simple experiment:

Hold your thumb out in front of you at arm’s length and look at it with your left eye closed. Now look at it with your right eye closed. As you look at your thumb, alternate which eye you close several times. You should see your thumb move relative to things in the background. Your thumb is not moving but your point of view is moving, so your thumb *appears* to move.

- *Goals:* to discuss the theory and practice of using parallax to find the distances to nearby stars, and use it to measure the distance to objects in the classroom
- *Materials:* classroom “ruler”, worksheets, ruler, protractor, calculator, small object

4.2 Parallax in the classroom

The “classroom parallax ruler” will be installed/projected on one side of the classroom. For the first part of this lab you will be measuring motions against this ruler.

Now work in groups: stand at the back of the room and have the TA place the parallax device on one of the tape marks along the line that goes straight to the front wall. You should be able to see the plastic stirrer against the background ruler. The observer should blink his/her eyes and measure the number of lines on the background ruler against which the object appears to move. **Note that you can estimate the motion measurement to a fraction of tick mark, e.g., your measurement might be 2 1/2 tick marks).** Do this for the three different marked distances. Switch places and do it again. Each person should estimate the motion for each of the three distances.

1. How many tick marks did the object move at the closest distance? **(2 points):**
2. How many tick marks did the object move at the middle distance? **(2 points):**
3. How many tick marks did the object move at the farthest distance? **(2 points):**
4. 'Parallax' is the term used for the apparent motion of the object against the background ruler. It is caused by looking at an object from two different vantage points. In this case, the two vantage points are the locations of your two eyes. Qualitatively, what do you see? As the object gets farther away, is the apparent motion smaller or larger? **(1 point):**
5. What if the vantage points are further apart? For example, imagine you had a huge head and your eyes were a foot apart rather than several inches apart. What would you predict for the apparent motion? **(1 point):**
Try the experiment again, this time using the object at one of the distances used above, but now measuring the apparent motion by using just one eye, but moving your whole head a few feet from side to side to get more widely separated vantage points.
6. How many tick marks does the object move as seen from the more widely separated vantage points? **(1 point):**
7. For an object at a fixed distance, how does the apparent motion change as you observe from more widely separated vantage points? **(1 point):**

4.3 Measuring distances using parallax

We have seen that the apparent motion depends on both the distance to an object and also on the separation of the two vantage points. We can then turn this around: if we can measure the apparent motion and also the separation of the two vantage points, we should be able to infer the distance to an object. This is very handy: it provides a way of measuring a distance without actually having to go to an object. Since we can't travel to them, this provides the only direct measurement of the distances to stars.

We will now see how parallax can be used to **determine the distances to the objects you looked at** just based on your measurements of their apparent motions and a measurement of the separation of your two vantage points (your two eyes).

4.3.1 Angular motion of an object

How can we measure the apparent motion of an object? As with our background ruler, we can measure the motion as it appears against a background object. But what are the appropriate units to use for such a measurement? Although we can measure how far apart the lines are on our background ruler, the apparent motion is not really properly measured in a unit of length; if we had put our parallax ruler further away, the apparent motion would have been the same, but the number of tick marks it moved would have been larger.

The apparent motion is really an *angular* motion. As such, it can be measured in *degrees*, with 360 degrees in a circle.

Figure out the angular separation of the tick marks on the ruler as seen from the opposite side of the classroom. Do this by putting one eye at the origin of one of the tripod-mounted protractors and measuring the angle from one end of the background ruler to the other end of the ruler. You might lay a pencil from your eye at the origin of the protractor toward each end and use this to measure the the total angle. Divide this angle by the total number of tick marks to figure out the angle for each tick mark.

1. Number of degrees for the entire background ruler (between the 0 and 20 marks):
2. Number of tick marks between 0 and 20 on the ruler:
3. Number of degrees in each tick mark:

Convert your measurements of apparent motion in tick marks from Section 4.2 to angular measurements by multiplying the number of tick marks by the number of degrees

per tick mark:

4. How many degrees did the object appear to move at the closest distance? **(2 points)**:

5. How many degrees did the object appear to move at the middle distance? **(2 points)**:

6. How many degrees did the object appear to move at the farthest distance? **(2 points)**:

4.3.2 Distance between the vantage points

Now you need to measure the distance between the two different vantage points, in this case, the distance between your two eyes. Have your partner measure this with a ruler. Since you see out of the pupil part of your eyes, you want to measure the distance between the centers of your two pupils.

1. What is the distance between your eyes? **(2 points)**

4.3.3 Using parallax measurements to determine the distance to an object

To determine the distance to an object for which you have a parallax measurement, you can construct an imaginary triangle between the two different vantage points and the object, as shown in Figure 4.1.

The angles you have measured correspond to the angle α on the diagram, and the distance between the vantage points (your pupils) corresponds to the distance b on the diagram. The distance to the object, which is what you want to figure out, is d .

The three quantities b , d , and α are related by a trigonometric function called the *tangent*. Now, you may have never heard of a *tangent*, if so don't worry—we will show you how to do this using another easy (but less accurate) way! But for those of you who are familiar with a little basic trigonometry, here is how you find the distance to an object using parallax: If you split your triangle in half (dotted line), then the tangent of $(\alpha/2)$ is equal to the quantity $(b/2)/d$:

$$\tan\left(\frac{\alpha}{2}\right) = \frac{(b/2)}{d}$$

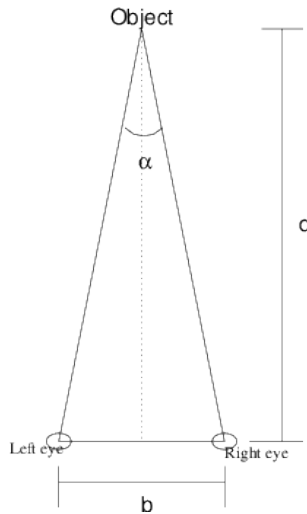

Figure 4.1: Parallax triangle

Rearranging the equation gives:

$$d = \frac{(b/2)}{\tan(\alpha/2)}$$

You can determine the tangent of an angle using your calculator by entering the angle and then hitting the button marked *tan*. There are several other units for measuring angles besides degrees (for example, radians), so you have to **make sure that your calculator is set up to use degrees** for angles before you use the tangent function.

Combine your measurements of angular distances and the distance between the vantage points to determine the three different distances to the parallax device. The units of the distances which you determine will be the same as the units you used to measure the distance between your eyes; if you measured that in inches, then the derived distances will be in inches.

Distance when object was at closest distance: **(2 points)**

Distance when object was at middle distance: **(2 points)**

Distance when object was at farthest distance: **(2 points)**

Now go and measure the actual distances to the locations of the objects using a yardstick, meterstick, or tape measure. How well did the parallax distances work? Can you think of any reasons why your measurements might not match up exactly? **(5 points)**

4.4 Using Parallax to measure distances on Earth, and within the Solar System

We just demonstrated how parallax works in the classroom, now let's move to a larger scale than the classroom.

4.4.1 The “Non-Tangent” way to figure out distances from angles

Because the angles in astronomical parallax measurement are very small, astronomers do not have to use the *tangent* function to determine distances from angles—they use something called the “small angle approximation formula”:

$$\frac{\theta}{57.3} = \frac{(b/2)}{d}$$

In this equation, we have defined $\theta = \alpha/2$, where α is the same angle as in the earlier equations (and in Fig. 4.1). Rearranging the equation gives:

$$d = \frac{57.3 \times (b/2)}{\theta}$$

To use this equation your parallax angle “ θ ” **has to be in degrees**. Now you can proceed to the next step!

1. *Using the small angle formula*, and your measured pupil distance, what would be the parallax angle (in degrees) for Organ Summit, the highest peak in the Organ mountains, if the Organ Summit is located 12 miles (or 20 km) from this classroom? [Hint: there are 5280 feet in a mile, and 12 inches in a foot. There are 1,000 meters in a km.]: **(3 points)**

You should have gotten a tiny angle! The smallest angle that the best human eyes can resolve is about 0.02 degrees. Obviously, our eyes provide an inadequate baseline for measuring this large of a distance. How can we get a bigger baseline? Well surveyors use a “transit” to carefully measure angles to a distant object. A transit is basically a small telescope mounted on a (fancy!) protractor. By locating the transit at two different spots separated by 100 yards (and carefully measuring this baseline!), they can get a much larger parallax angle, and thus it is fairly easy to measure the distances to faraway trees, mountains, buildings or other large objects.

How about an object in the Solar System? We will use Mars, the planet that comes closest to Earth. At favorable oppositions, Mars gets to within about 0.4 AU of the Earth. Remember, 1 AU is the average distance between the Earth and Sun: 149,600,000 km.

2. Calculate the parallax angle for Mars (using the small angle approximation) using a baseline of 1000 km. **(3 points)**

4.5 Distances to stars using parallax, and the “Parsec”

Because stars are very far away, the parallax motion will be very small. For example, the nearest star is about 1.9×10^{13} miles or 1.2×10^{18} inches away! At such a tremendous distance, the apparent angular motion is very small. Considering the two vantage points of your two eyes, the angular motion of the nearest star corresponds to the apparent diameter of a human hair seen at the distance of the Sun! This is a truly tiny angle and totally unmeasurable by your eye.

Like a surveyor, we can improve our situation by using two more widely separated vantage points. The two points farthest apart we can use from Earth is to use two opposite points in the Earth’s orbit about the Sun. In other words, we need to observe a star at two different times separated by six months. The distance between our two vantage points, b , will then be twice the distance between the Earth and the Sun: “2 AU”. Figure 4.2 shows the idea.

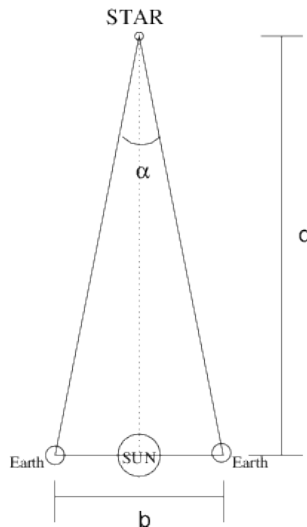

Figure 4.2: Parallax Method for Distance to a Star

Using 299.2 million km as the distance b , we find that the apparent angular motion (α) of even the nearest star is only about 0.0004 degrees. This is also unobservable using your naked eye, which is why we cannot directly observe parallax by looking at stars with our

naked eye. However, this angle is relatively easy to measure using modern telescopes and instruments.

Time to talk about a new distance unit, the “Parsec”. Before we do so, we have to review the idea of smaller angles than degrees. Your TA or professor might already have mentioned that a degree can be broken into 60 arcminutes. Thus, instead of saying the parallax angle is 0.02 degrees, we can say it is 1.2 arcminutes. But note that the nearest star only has a parallax angle of 0.024 arcminutes. We need to switch to a smaller unit to keep from having to use scientific notation: the arcsecond. There are 60 arcseconds in an arcminute, thus the parallax angle (α) for the nearest star is 1.44 arcseconds. To denote arcseconds astronomers append a single quotation mark (”) at the end of the parallax angle, thus $\alpha = 1.44''$ for the nearest star. But remember, in converting an angle into a distance (using the tangent or small angle approximation) we used the angle $\alpha/2$. So when astronomers talk about the parallax of a star they use this angle, $\alpha/2$, which we called “ θ ” in the small angle approximation equation.

How far away is a star that has a parallax angle of $\theta = 1''$? The answer is 3.26 light years, and this distance is defined to be “1 Parsec”. The word Parsec comes from **Par**allax **Sec**ond. An object at 1 Parsec has a parallax of $1''$. An object at 10 Parsecs has a parallax angle of $0.1''$. Remember, the further away an object is, the smaller the parallax angle.

The nearest star (Alpha Centauri) has a parallax of $\theta = 0.78''$, and is thus at a distance of $1/\theta = 1/0.78 = 1.3$ Parsecs.

Depending on your professor, you might hear the words Parsec, kiloparsec, Megaparsec and even Gigaparsec in your lecture classes. These are just shorthand methods of talking about distances in astronomy. A kiloparsec is 1,000 Parsecs, or 3,260 light years. A Megaparsec is one million parsecs, and a Gigaparsec is one billion parsecs. To convert to light years, you simply have to multiply by 3.26. The Parsec is a strange unit, but you have already encountered other strange units this semester!

Let’s work some examples. Remember:

- **1 Parsec = 3.26 lightyears**
- **distance (in Parsecs) = $\frac{1}{\theta}$ (in arcseconds)**

1. If a star has a parallax angle of $\theta = 0.25''$, what is its distance in Parsecs? **(1 point)**
2. If a star is at a distance of 5 Parsecs, what is its parallax angle? **(1 point)**
3. If a star is at a distance of 5 Parsecs, how many light years away is it? **(1 point)**

4.6 Questions

1. How does the parallax angle change as an object is moved further away? Given that you can usually only measure an angular motion to some accuracy, would it be easier

to measure the distance to a nearby star or a more distant star? Why? **(4 points)**

2. Relate the experiment you did in lab to the way parallax is used to measure the distances to nearby stars in astronomy. Describe the process an astronomer has to go through in order to determine the distance to a star using the parallax method. What do your two eyes represent in that experiment? **(5 points)**
3. Imagine that you did the classroom experiment by putting the object all the way at the front of the room (against the ruler). How big would the apparent motion be relative to the tick marks? What would you infer about the distance to the object? Why do you think this estimate is incorrect? What can you infer about where the background objects in a parallax experiment need to be located? **(7 points)**
4. Imagine that you observe a star field twice one year, separated by six months and observe the configurations of stars shown in Figure 4.3:



Figure 4.3: Star field seen at two times of year six months apart.

The star marked P appears to move between your two observations because of parallax. So you can consider the two pictures to be like our lab experiment where the left picture is what is seen by one eye and the right picture what is seen by the other eye. All the stars except star P do not appear to change position; they correspond to the background ruler in our lab experiment. If the angular distance between stars A and B is 0.5 arcminutes (remember, 60 arcminutes = 1 degree), then how far away would you estimate that star P is?

- (a) Determine the scale: Measure the distance (in cm) between stars A and B . (This distance corresponds to an angular separation of 0.5 arcminutes)
- (b) Measure how much star P moved (in cm)
- (c) Convert this measured distance to an angular distance in arcminutes (using the scale found in part a).
- (d) Convert your angular distance from arcminutes to arcseconds (remember, there are 60 arcseconds in 1 arcminute).

(e) What is the value of θ ? (Recall that $\theta = \frac{\alpha}{2}$)

(f) Using the parallax equation ($d = \frac{1}{\theta}$) find the distance to the star P .

(11 points)

4.7 Summary (35 points)

Please summarize the important concepts discussed in this lab. Your summary should include:

- A brief description on the basic principles of parallax and how astronomers can use parallax to determine the distance to nearby stars

Also think about and answer the following questions:

- Does the parallax method work for all stars we can see in our Galaxy and why?
- Why do you think it is important for astronomers to determine the distances to the stars which they study?

Use complete sentences, and proofread your summary before handing in the lab.

4.8 Possible Quiz Questions

- 1) How do astronomers measure distances to stars?
- 2) How can astronomers measure distances inside the Solar System?
- 3) What is an Astronomical Unit?
- 4) What is an arcminute?
- 5) What is a Parsec?

4.9 Extra Credit (ask your TA for permission before attempting, 5 points)

Use the web to find out about the planned GAIA Mission. What are the goals of GAIA? How accurately can it measure a parallax? Discuss the units of milliarcseconds (“mas”) and microarcseconds. How much better is GAIA than the best ground-based parallax measurement programs?

Name: _____

Date: _____

5 Characterizing Exoplanets

5.1 Introduction

Exoplanets are a hot topic in astronomy right now. As of December 19th, 2024, there were over 5811 known exoplanets with several thousand candidates waiting to be confirmed. These exoplanets and exoplanet systems are of great interest to astronomers as they provide information on planet formation and evolution, as well as the discovery of a variety of types of planets not found in our solar system. A small subset of these planetary systems are of interest for another reason: They may support life. In this lab you will analyze observations of exoplanets to fully characterize their nature. At the end, you will then compare your results with simulated images of these exoplanets to see how well you performed. Note that the capabilities required to intensely study exoplanets have not yet been built and launched into space. But we know enough about optics that we can envision a day when advanced space telescopes, like those needed for the conclusion of today's lab, will be in Earth orbit and will directly image these objects, as well as obtain spectra to search for the chemical signatures of life.

5.2 Types of Exoplanets

As you have learned in class this semester, our solar system has two main types of planets: Terrestrial (rocky) and Jovian (gaseous). Because these were the only planets we knew about, it was hard to envision what other kinds of planets might exist. Thus, when the first exoplanet was discovered, it was a shock for astronomers to find out that this object was a gas giant like Jupiter, but had an orbit that was even smaller than that of Mercury! This led to a new kind of planet called "Hot Jupiters". In the two decades since the discovery of that first exoplanet, several other new types of planets have been recognized. Currently there are six major classes that we list below. We expect that other types of planets will be discovered as our observational techniques improve.

5.2.1 Gas Giants

Gas giants are planets similar to Jupiter, Saturn, Uranus, and Neptune. They are mostly composed of hydrogen and helium with possible rocky or icy cores. Gas giants have masses greater than 10 Earth masses. Roughly 25 percent of all discovered exoplanets are gas giants.

5.2.2 Hot Jupiters

Hot Jupiters are gas giants that either formed very close to their host star or formed farther out and "migrated" inward. If there are multiple planets orbiting a star, they can interact through their gravity. This means that planets can exchange energy, causing their orbits to expand or to shrink. Astronomers call this process migration, and we believe it happened

early in the history of our own solar system. Hot Jupiters are found within 0.05-0.5 AU of their host star (remember that the Earth is at 1 AU!). As such, they are extremely hot (with temperatures as high as 2400 K), and are the most common type of exoplanet found; about 50 percent of all discovered exoplanets are Hot Jupiters. This is due to the fact that the easiest exoplanets to detect are those that are close to their host star and very large. Hot Jupiters are both.

5.2.3 Water Worlds

Water worlds are exoplanets that are completely covered in water. Simulations suggest that these planets actually formed from debris rich in ice further from their host star. As they migrated inward, the water melted and covered the planet in a giant ocean.

5.2.4 Exo-Earths

Exo-Earths are planets just like the Earth. They have a similar mass, radius, and temperature to the Earth, orbiting within the “habitable zone” of their host stars. Only a very small number of Exo-Earth candidates have been discovered as they are the hardest type of planet to discover.

5.2.5 Super-Earths

Super-Earths are potentially rocky planets that have a mass greater than the Earth, but no more than 10 times the mass of the Earth. “Super” only refers to the mass of the planet and has nothing to do with anything else. Therefore, some Super Earths may actually be gas planets similar to (slightly) smaller versions of Uranus or Neptune.

5.2.6 Chthonian Planets

“Chthonian” is from the Greek meaning “of the Earth.” Chthonian Planets are exoplanets that used to be gas giants but migrated so close to their host star that their atmosphere was stripped away leaving only a rocky core. Due to their similarities, some Super Earths may actually be Chthonian Planets.

5.3 Detection Methods

There are several methods used to detect exoplanets. The most useful ones are listed below.

5.3.1 Transit Method/Light Curves

The transit method attempts to detect the “eclipse” of a star by a planet that is orbiting it. Because planets are tiny compared to their host stars, these eclipses are very small, requiring extremely precise measurements. This is best done from space, where observations can be made continuously, as there is no night or day, or clouds to get in the way. This is the detection method used by the *Kepler* Space Telescope. *Kepler* stared at a particular patch of sky and observed over a hundred thousand stars continuously for more than four years.

It measured the amount of light coming from each star. It did this over and over, making a new measurement every 30 minutes. Why? If we were looking back at the Sun and wanted to detect the Earth, we would only see one transit per year! Thus, you have to continuously stare at the star to insure you do not miss this event (as you need at least three of these events to determine that the exoplanet is real, and to measure its orbital period). The end result is something called a “light curve”, a graph of the brightness of a star over time. The entire process is diagrammed in Figure 5.4. We will be exclusively using this method in lab today.

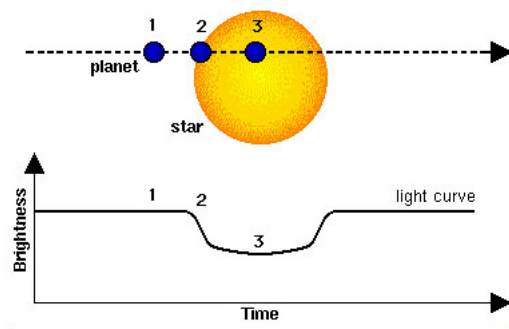

Figure 5.4: The diagram of an exoplanet transit. The planet, small, dark circle, crosses in front of the star as seen from Earth. In the process, it blocks out some light. The light curve, shown on the bottom, is a plot of brightness versus time, and shows that the star brightness is steady until the exoplanet starts to cover up some of the visible surface of the star. As it does so, the star dims. It eventually returns back to its normal brightness only to await the next transit.

In Figure 5.4, there is a dip in the light curve, signifying that an object passed between the star and our line of sight. If, however, *Kepler* continues to observe that star and sees the same sized dip in the light curve on a periodic basis, then it has probably detected an exoplanet (we say “probably” because a few other conditions must be met for it to be a confirmed exoplanet). The amount of star light removed by the planet is very small, as all planets are much, much smaller than their host stars (for example, the radius of Jupiter is 11 times that of the Earth, but it is only 10% the radius of the Sun, or 1% of the area = *how much the light dims*). Therefore, it is much easier to detect planets that are larger because they block more of the light from the star. It is also easier to detect planets that are close to their host star because they orbit quickly so *Kepler* could observe several dips in the light curve each year.

5.3.2 Direct Detection

Direct detection is exactly what it sounds like. This is the method of imaging (taking a picture) of the planets around another star. But we cannot simply point a telescope at a star and take a picture because the star is anywhere from 100 million (10^8) to 100 billion (10^{11})

times brighter than its exoplanets. In order to combat the overwhelming brightness of a star, astronomers use what is called a “coronagraph” to block the light from the star in order to see the planets around it. You may have already seen images made with a coronagraph to see the “corona” of the Sun in the Sun lab.

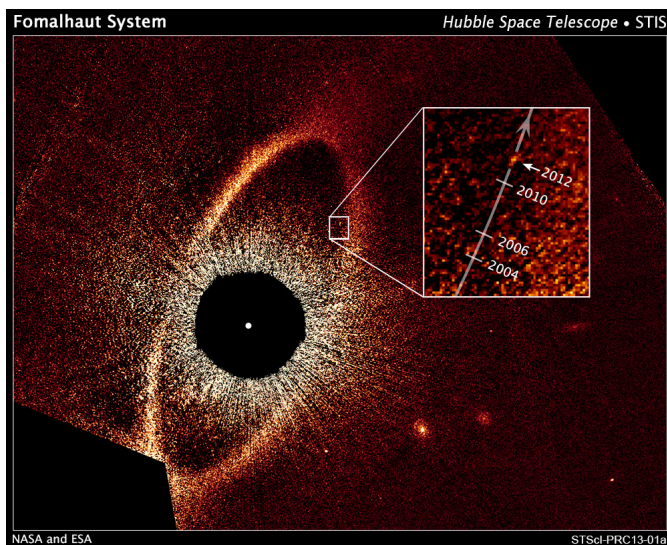

Figure 5.5: A coronagraphic image of an exoplanet orbiting the star Fomalhaut (inside the box, with the arrow labeled “2012”). This image was obtained with the Hubble Space Telescope, and the star’s light has been blocked-out using a small metal disk. Fomalhaut is also surrounded by a dusty disk of material—the broad band of light that makes a complete circle around the star. This band of dusty material is about the same size as the Kuiper belt in our solar system. The planet, “Fomalhaut B”, is estimated to take 1,700 years to orbit once around the star. Thus, using Kepler’s third law ($P^2 \propto a^3$), it is roughly about 140 AU from Fomalhaut (remember that Pluto orbits at 39.5 AU from the Sun).

So if astronomers can block the light from the Sun to see its corona, they should be able to block the light from distant stars to see the exoplanets right? While this is true, directly seeing exoplanets is difficult. There are two problems: the exoplanet only shines by reflected light, and it is located very, very close to its host star. Thus, it takes highly specialized techniques to directly image exoplanets. However, for some of the closest stars this can be done. An example of direct exoplanet detection is shown in Figure 5.5. A new generation of space-based telescopes that will allow us to do this for many more stars is planned. Eventually, we should be able to take both spectra (to determine their composition) and direct images of the planets themselves. We will pretend that we can obtain good images of exoplanets later in lab today.

5.3.3 Radial Velocity (Stellar Wobble)

The radial velocity or “stellar wobble” method involves measuring the Doppler shift of the light from a particular star and seeing if the lines in its spectrum oscillate periodically

between a red and blue shift. As a planet orbits its star, the planet pulls on the star gravitationally just as the star pulls on the planet. Thus, as the planet goes around and around, it slightly tugs on the star and makes it wobble, causing a back and forth shift in its radial velocity, the motion we see towards and away from us. Therefore, if astronomers see a star wobbling back and forth on a repeating, periodic timescale, then the star has at least one planet orbiting around it. The size of the wobble allows astronomers to calculate the mass of the exoplanet.

5.4 Characterizing Exoplanets from Transit Light Curves

Quite a bit of information about an exoplanet can be gleaned from its transit light curve. Figure ?? shows how a little bit of math (from Kepler’s laws), and a few measurements, can tell us much about a transiting exoplanet.

The equations shown in Figure ?? are complicated by the fact that exoplanets do not orbit their host stars in perfect circles, and that the transit is never exactly centered. Today we are going to only study planets that have circular orbits, and whose orbital plane is edge-on. Thus, all of the terms with “ $\cos i$ ” (“ i ” is the inclination of the orbit to our sight line, and $i = 0^\circ$ for edge on), $\cos \delta$ or $\sin \delta$ (δ is the transit latitude, here $\delta = 90^\circ$), and “ e ” (which is the eccentricity, the same orbital parameter you have heard about in class for our solar system planets, or in the orbit of Mercury lab, for circular orbits $e = 1.0$) are equal to “1” or “0”.

First, let’s remember Kepler’s third law $P^2 \propto a^3$, where P is the orbital period, and a is the semi-major axis. For Earth, we have $P = 1$ yr, $a = 1$ AU. By taking ratios, you can figure out the orbital periods and semi-major axes of other planets in *our* solar system. Here we cannot do that, and we need to use Isaac Newton’s reformulation of Kepler’s third law:

$$P^2 = \frac{4\pi^2 a^3}{G(M_{star} + M_{planet})} \quad (1)$$

“ G ” in this equation is the gravitational constant ($G = 6.67 \times 10^{-11}$ Newton-m²/kg²), and $\pi = 3.14$.

We also have to estimate the size of the planet. As detailed in Fig. ??, the depth of the “eclipse” gives us the ratio of the radius of the planet to that of the star:

$$\frac{\Delta F}{F} = \left(\frac{R_{planet}}{R_{star}} \right)^2 \quad (2)$$

Now we have everything we need to use transits to characterize exoplanets. We will have to re-arrange equations 1 and 2 so as to extract unknown parameters where the other variables are known from measurements.

5.5 Deriving Parameters from Transit Light Curves

The orbital period of the exoplanet is the easiest parameter to measure. In Figure 5.6 is the light curve of “Kepler 1b”, the first of the exoplanets examined by the *Kepler* mission. Kepler 1b is a Hot Jupiter, so it has a deep transit. You can see from the figure that transits recur every 2.5 days. That is the orbital period of the planet. It is very easy to figure out orbital periods, so we will not be doing that in this lab today.

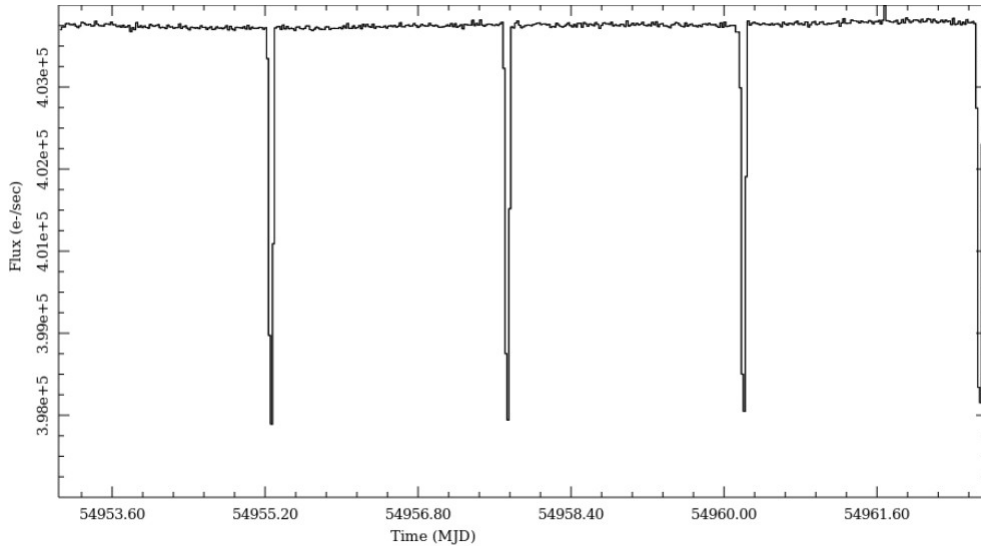

Figure 5.6: The light curve of Kepler 1b as measured by the *Kepler* satellite. The numbers on the y-axis are the total counts (how much light was measured), while the x-axis is “modified Julian days”. This is a system that simply makes it easy to figure out periods of astronomical events since it is a number that increases by 1 every day (instead of figuring out how many days there were between June 6th and November 3rd). Thus, to get an orbital period you just subtract the MJD of one event from the MJD of the next event.

In the following eight figures are the light curves of eight different transiting exoplanets. Today you will be using these light curves to determine the properties of transiting exoplanets. To help you through this complicated process, the data for exoplanet #8 will be worked out at each step below. You will do the same process for one of the other seven transiting exoplanets. Your TA might assign one to you, or you will be left to choose one. Towards the end of today’s exercise your group will classify both of these exoplanets. Each panel lists the orbital period of the exoplanets (“xxx day orbit”), ranging from 3.89 days for exoplanet #3, to 3.48 years for exoplanet #2. You should be able to guess what that means already: one is close to its host star, the other far away. The other information contained in these figures is a measurement of “t”, the total time of the transit (“eclipse takes xxx hours”). When working with the equations below, all time units must be in seconds! Remember, 3600 seconds per hour, 24 hours per day, 365 days per year (there are 3.15×10^7 seconds per year).

Exercise #1:

- The first quantity we need to calculate is the size of the planet with respect to the host star. How do we do that? Go back to Figure ???. We need to measure “ $\Delta F/F$ ”. The data points in the exoplanet light curves have been fit with a transit model (the solid line fit to the data points) to make it easy to measure the *minimum*. For both of the transits, take a ruler and determine the value on the y axis by drawing a line across the model fit to the light curve minimum. Estimate this number as precisely as possible, then subtract this number from 1, and you get $\Delta F/F$. (2 points)

$\Delta F/F$ for transit # _____ = _____

$\Delta F/F$ for transit #8 = _____ 0.00153

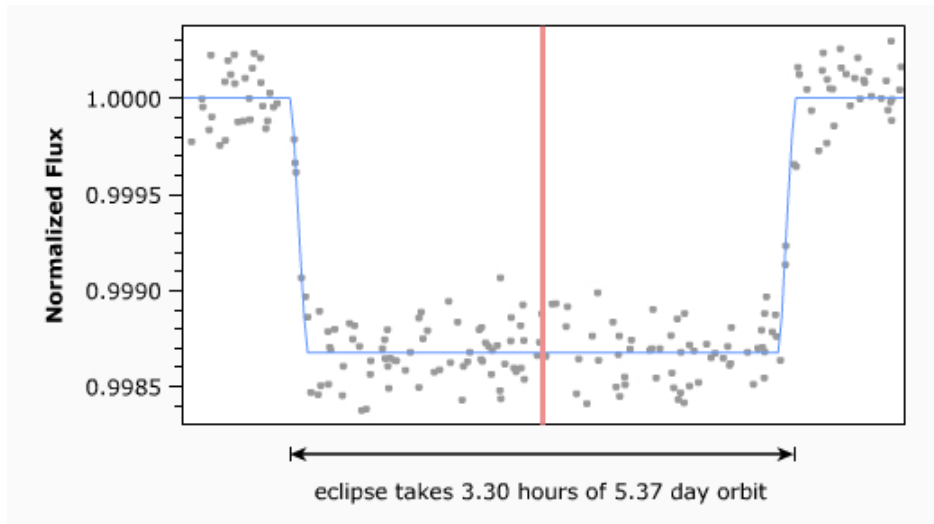

Figure 5.7: Transiting exoplanet #1. The vertical line in the center of the plot simply identifies the center of the eclipse.

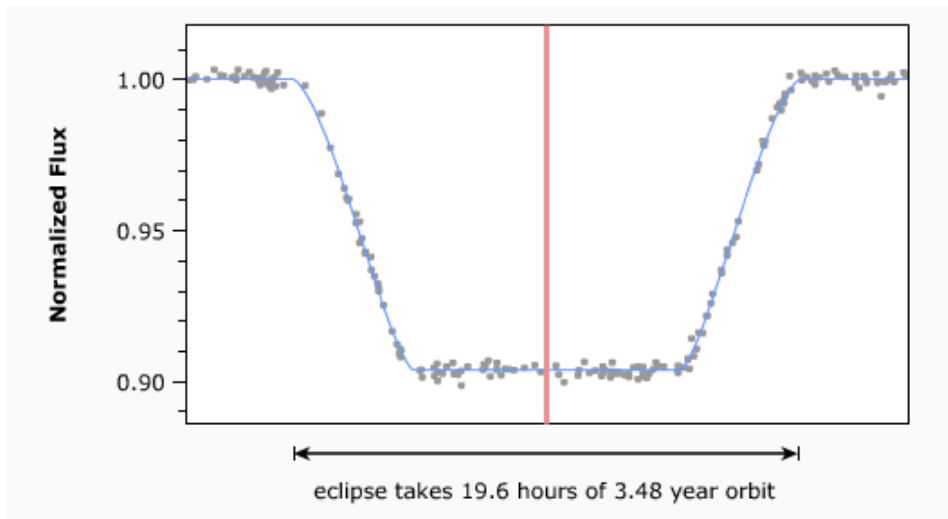

Figure 5.8: Transiting exoplanet #2.

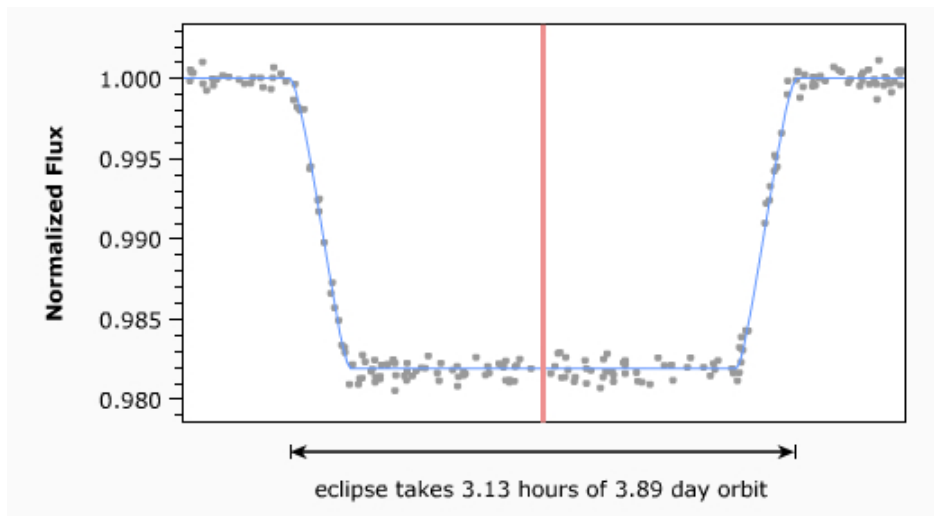

Figure 5.9: Transiting exoplanet #3.

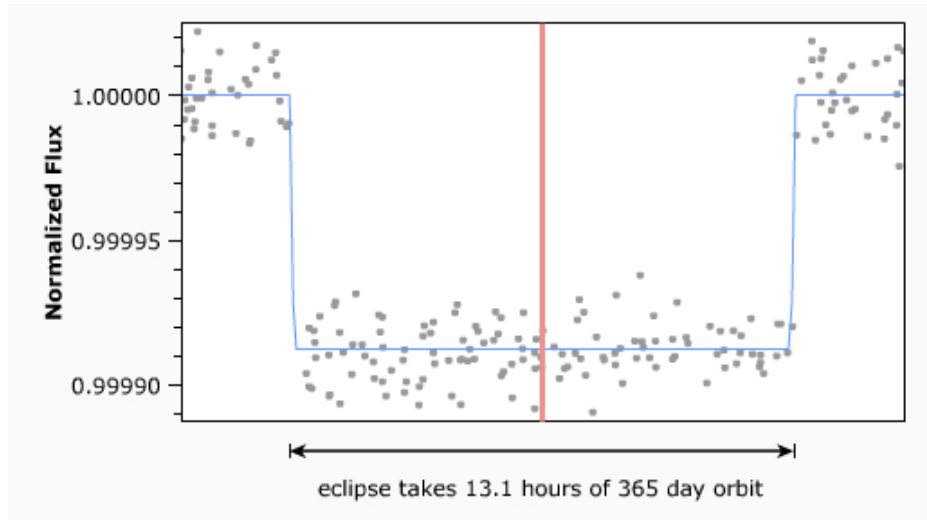

Figure 5.10: Transiting exoplanet #4.

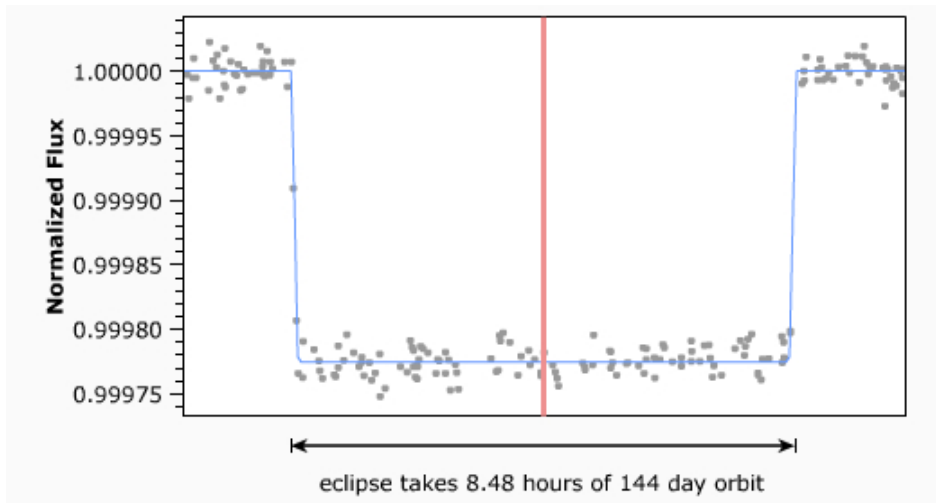

Figure 5.11: Transiting exoplanet #5.

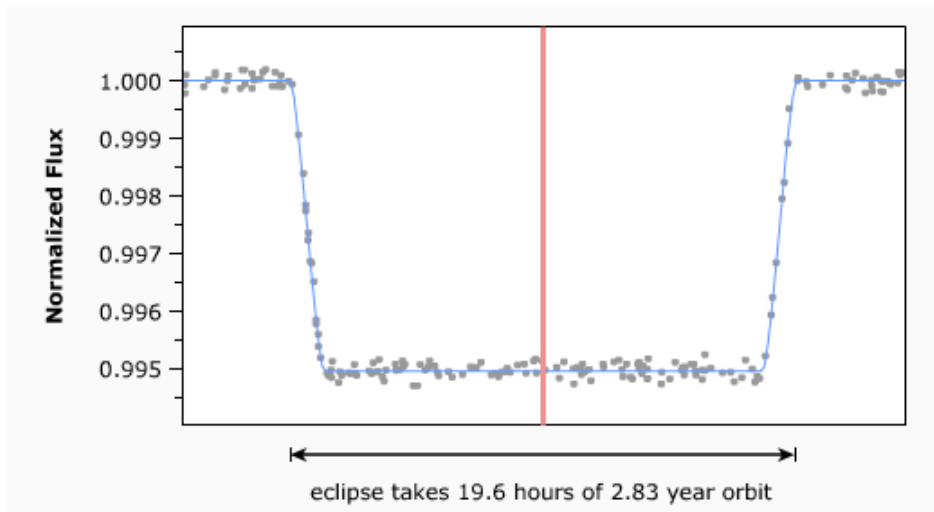

Figure 5.12: Transiting exoplanet #6.

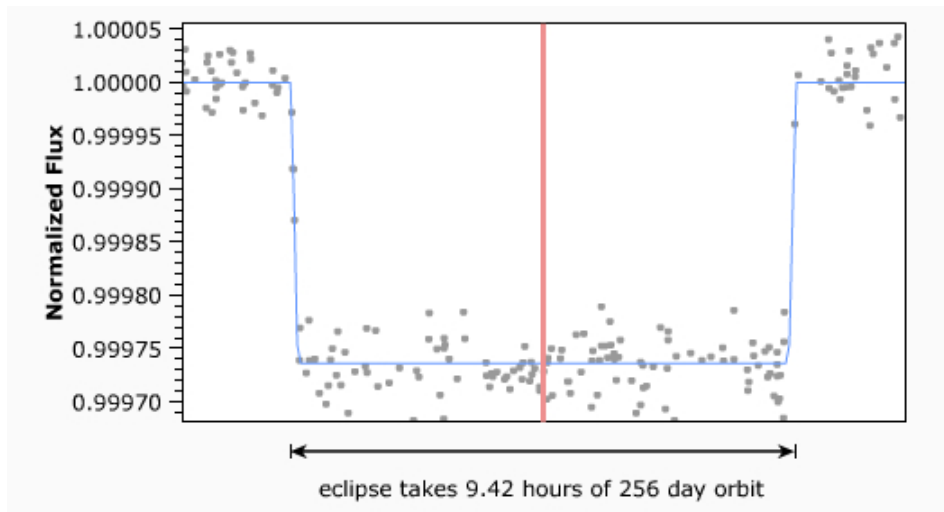

Figure 5.13: Transiting exoplanet #7.

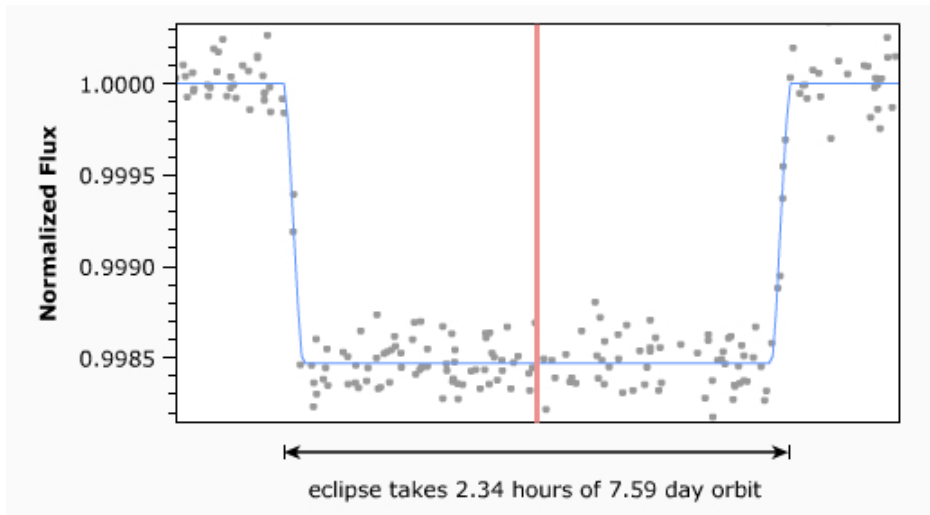

Figure 5.14: Transiting exoplanet #8.

Going back to equation #2, we have:

$$\frac{\Delta F}{F} = \left(\frac{R_{planet}}{R_{star}} \right)^2 \quad \text{or} \quad R_{planet} = \left(\frac{\Delta F}{F} \right)^{1/2} (\times R_{star})$$

2. Taking the square roots of the $\Delta F/F$ from above, fill in the following blanks (**4 points**):

$$R_{planet} \text{ for transit \# } \underline{\hspace{2cm}} = \underline{\hspace{2cm}} (\times R_{star})$$

$$R_{planet} \text{ for transit } \underline{\hspace{1cm}} \#8 = \underline{\hspace{1cm}} 0.0391 \underline{\hspace{1cm}} (\times R_{star})$$

You just calculated the relative sizes of the planets to their host stars. To turn these into real numbers, we have to know the sizes of the host stars. Astronomers can figure out the masses, radii, temperatures and luminosities of stars by combining several techniques (photometry, parallax, spectroscopy, and interferometry). Note that stars can have dramatically different values for their masses, radii, temperatures and luminosities, and these directly effect the parameters derived for their exoplanets. The data for the eight exoplanet host stars are listed in Table 5.1. The values for our Sun are $M_{\odot} = 2 \times 10^{30}$ kg, $R_{\odot} = 7 \times 10^8$ m, $L_{\odot} = 4 \times 10^{26}$ Watts.

Table 5.1: Exoplanet Host Star Data

Object	Mass (kg)	Radius (meters)	Temperature (K)	Luminosity (Watts)
#1	2.0×10^{30}	7.00×10^8	5800	4.0×10^{26}
#2	1.3×10^{30}	4.97×10^8	4430	2.8×10^{25}
#3	2.2×10^{30}	7.56×10^8	6160	1.2×10^{27}
#4	2.0×10^{30}	7.00×10^8	5800	4.0×10^{26}
#5	1.6×10^{30}	5.88×10^8	5050	2.4×10^{26}
#6	2.0×10^{30}	7.00×10^8	5800	4.0×10^{26}
#7	1.4×10^{30}	5.25×10^8	4640	4.8×10^{25}
#8	1.0×10^{30}	3.99×10^8	3760	4.0×10^{24}

3. Now that you calculated the radius of the exoplanet with respect to the host star radius, use the data in Table 5.1 to convert the radii of your planet into meters, and put this value in the correct row and column in Table 5.2. (**5 points**)

4. Astronomer Judy, and her graduate student Bob, used the spectrograph on the Keck telescope in Hawaii to measure the masses of your planets using the radial velocity technique mentioned above. So we have entered their values for the masses for all of the exoplanets in Table 5.2. You need to calculate the density of your exoplanet and enter it in the correct places in Table 5.2. Remember that density = mass/volume,

Table 5.2: Exoplanet Data

Object	Radius (m)	Semi-major axis (m)	Mass (kg)	Density (kg/m ³)	Temperature (K)
#1			1.9×10^{26}		
#2			1.9×10^{28}		
#3			5.7×10^{27}		
#4			6.0×10^{24}		
#5			1.5×10^{25}		
#6			8.0×10^{26}		
#7			4.0×10^{24}		
#8	1.6×10^7	9.0×10^9	5.5×10^{25}	3205	555

and the volume of all of the planets is $V = 4\pi R^3/3$, as we know that they all must be spherical. **(5 points)**

5. By calculating the density, you already know something about your planets. Remember that the density of Jupiter is 1326 kg/m^3 and the density of the Earth is 5514 kg/m^3 . If you did the Density lab this semester, we used the units of gm/cm^3 , where water has a density of 1.00 gm/cm^3 . This is the “cgs” system of units. To get from kg/m^3 to gm/cm^3 , you simply divide by 1000. Describe how the densities of your two exoplanets compare with the Earth and/or Jupiter. **(5 points)**

The next parameter we want to calculate is the semi-major axis “ a ”. While we now know the size and densities of our planets, we do not know how hot or cold they are. We need to figure out how far away they are from their host stars. To do this we re-arrange equation #1, and we get this:

$$a = \left(\frac{P^2 G (M_{star} + M_{planet})}{4\pi^2} \right)^{1/3} = (1.69 \times 10^{-12} P^2 M_{star})^{1/3}$$

6. You must use seconds for P , and kg for the mass of the star (note: you can ignore the mass of the planet since it will be very small compared to the star). We have simplified the equation by bundling G and $4\pi^2$ into a single constant. Note that you have to take the cube root of the quantity inside the parentheses. We write the cube root as an exponent of “ $1/3$ ”. Ask your TA for help on this step. Fill in the column for semi-major axis in Table 5.2 for your exoplanet. **(5 points)**

5.6 The Habitable Zone

The habitable zone is the region around a star in which the conditions are just right for a planet to have liquid water on its surface. Here on Earth, all life must have access to liquid water to survive. Therefore, a planet is considered “habitable” if it has liquid water. This zone is also colloquially known as the “Goldilocks Zone”.

To figure out the temperature of a planet is actually harder than you might think. We know how much energy the exoplanet host stars emit, as that is what we call their luminosities. We also know how far away your exoplanets are from this energy source (the semi-major axis). The formula to estimate the “equilibrium temperature” of an exoplanet with a semi-major axis of a around a host star with known parameters is:

$$T_{planet} = T_{star}(1.0 - A)^{1/4} \left(\frac{R_{star}}{2a} \right)^{1/2} \quad (3)$$

The “A” in this equation is the “Albedo,” how much of the energy intercepted by a planet is reflected back into space. Equation #3 is not too hard to derive, but we do not have enough time to explain how it arises. You can ask your professor, or search Wikipedia using the term “Planetary equilibrium temperature” to find out where this comes from. The big problem with using this equation is that different atmospheres create different effects. For example, Venus reflects 67% of the visible light from the Sun, yet is very hot. The Earth reflects 39% of the visible light from the Sun and has a comfortable climate. It is how the atmosphere “traps heat” that helps determine the surface temperature. Alternatively, a planet might not even have an atmosphere and could be bright or dark with no heat trapping (for example, the Albedo of the moon is 0.11, as dark as asphalt, and the surface is boiling hot during the day, and extremely cold at night).

Let’s demonstrate the problem using the Earth. If we use the value of $A = 0.39$ for Earth, equation #3 would predict a temperature of $T_{Earth} = 247$ K. But the mean temperature on the Earth is actually $T_{Earth} = 277$ K. Thus, the atmosphere on Earth keeps it warmer than the equilibrium temperature. This is true for just about any planet with a significant atmosphere. To account for this effect, let’s go backwards and solve for “A”. With $R_{\odot} = 7.0 \times 10^8$ m, $a = 1.50 \times 10^{11}$ m, $T_{Earth} = 277$ K, and $T_{\odot} = 5800$ K, we find that $A = 0.05$. Thus, the Earth’s atmosphere makes it seem like we absorb 95% of the energy from the Sun. We will presume this is true for all of our planets.

If we assume $A = 0.05$, equation #3 simplifies to:

$$T_{planet} = 0.70 \left(\frac{R_{star}}{a} \right)^{1/2} T_{star} \quad (4)$$

[To understand what we did here, note that $(1.0 - A) = 0.95$. The fourth root of $0.95 = 0.95^{1/4} = 0.99$ (remember the fourth root is two successive square roots: $\sqrt{0.95} = 0.95^{1/2} = 0.97$, and $0.97^{1/2} = 0.99$). We then divided 0.99 by $\sqrt{2}$ ($= 1.41$) to have a single constant out front.]

7. Calculate the temperature of your exoplanet using equation #4 and enter it into Table 5.2. (5 points)

As we said, the habitable zone is the region around a star of a particular luminosity where water might exist in a liquid form somewhere on a planet orbiting that star. The Earth ($a = 1$ AU) sits in the habitable zone for the Sun, while Venus is too close to the Sun ($a = 0.67$ AU) to be inside the habitable zone, while Mars ($a = 1.52$ AU) is near the outer edge. As we just demonstrated, the atmosphere of a planet can radically change the location of the habitable zone. Mars has a very thin atmosphere, so it is very cold there and all of its water is frozen. If Mars had the thick atmosphere of Venus, it would probably have abundant liquid water on its surface. As we noted, the mean temperature of Earth is 277 K, but the polar regions have average temperatures well below freezing ($32^\circ\text{F} = 273$ K) with an average annual temperature at the North pole of 263 K, and 228 K at the South pole. The equatorial regions of Earth meanwhile have average temperatures of 300 K. So for just about every planet there will be wide ranges in surface temperature, and liquid water could exist somewhere on that planet.

8. Given that your temperature estimates are not very precise, we will consider your planet to be in the habitable zone if its temperature is between 200K and 350 K. Is either of your planets in the habitable zone? (**4 points**)

5.7 Classifying Your Exoplanets

At the beginning of today's lab we described the several types of exoplanet classes that currently exist. We now want you to classify your exoplanet into one of these types. To help you decide, in Table 5.3 we list the parameters of the planets in our solar system. After you have classified them, you will ask your TA to see "images" of your exoplanets to check to see how well your classifications turned out.

9. Compare the radii, the semi-major axes, the masses, densities and temperatures you found for your two exoplanets to the values found in our solar system. For example, if the radius of one of your exoplanets was 8×10^7 , and its mass was 2.5×10^{27} it is similar in "size" to Jupiter. But it could have a higher or lower density, depending on composition, and it might be hotter than Mercury, or colder than Mars. Fully describe your two exoplanets. (**10 points**)

Table 5.3: Solar System Data

Object	Radius (m)	Semi-major axis (m)	Mass (kg)	Density (kg/m ³)	Temperature (K)
Mercury	2.44×10^6	5.79×10^{10}	3.3×10^{23}	5427	445
Venus	6.05×10^6	1.08×10^{11}	4.9×10^{24}	5243	737
Earth	6.37×10^6	1.49×10^{11}	5.9×10^{24}	5514	277
Mars	3.39×10^6	2.28×10^{11}	6.4×10^{23}	3933	210
Jupiter	6.99×10^7	7.78×10^{11}	1.9×10^{27}	1326	122
Saturn	6.03×10^7	1.43×10^{12}	5.7×10^{26}	687	90
Uranus	2.54×10^7	2.87×10^{12}	8.7×10^{25}	1270	63
Neptune	2.46×10^7	4.50×10^{12}	1.0×10^{26}	1638	50
Pluto	1.18×10^6	5.87×10^{12}	1.3×10^{22}	2030	43

As Table 5.3 shows you, there are two main kinds of planets in our solar system: the rocky Terrestrial planets with relatively thin atmospheres, and the Jovian planets, which are gas giants. Planets with high densities ($> 3000 \text{ kg/m}^3$) are probably like the Terrestrial planets. Planets with low densities ($< 3000 \text{ kg/m}^3$) are probably mostly gaseous or have large amounts of water (Pluto has a large fraction of its mass in water ice).

10. Given your discussion from the previous question, and the discussion of the types of exoplanets in the introduction, classify your two exoplanets into one of the following categories: 1) Gas giant, 2) Hot Jupiter, 3) Water world, 4) Exo-Earth, 5) Super-Earth, or 6) Chthonian. What do you expect them to look like? (**10 points**)

11. Your TA has images for all eight exoplanets of this lab obtained from NASA's "Exoplanet Imager" mission that was successfully launched in 2040. Were your predictions correct? Yes/no. If no, what went wrong? [The TA also has the data for all of the exoplanets to help track down any errors.] (**10 points**)

Name: _____

Date: _____

5.8 Take Home Exercise (35 points total)

Please summarize the important concepts discussed in this lab. Your summary should include:

- Discuss the different types of exoplanets and their characteristics.
- What are the measurements required for you to determine the most important parameters of an exoplanet?
- What requirement for an exoplanet gives it the possibility of harboring life?

Use complete sentences, and proofread your summary before handing in the lab.

5.9 Possible Quiz Questions

1. What are some of the different types of exoplanets?
2. What are some different exoplanet detection methods?
3. What is the habitable zone?

5.10 Extra Credit (ask your TA for permission before attempting, 5 points)

Your TA has the data for all of the exoplanets for today's lab. With that data, go back and answer questions #8 and #9 for all of the exoplanets.

Acknowledgement: This lab was made possible using the Extrasolar Planets Module of the Nebraska Astronomy Applet Project.

Name: _____

Date: _____

6 The Hertzsprung-Russell Diagram

6.1 Introduction

As you may have learned in class, the Hertzsprung-Russell Diagram, or the “HR diagram”, is one of the most important tools used by astronomers: it helps us determine both the ages of star clusters and their distances. In your Astronomy 110 textbooks the type of HR diagram that you will normally encounter plots the Luminosity of a star (in solar luminosity units, L_{Sun}) versus its temperature (or spectral type). An example is shown here:

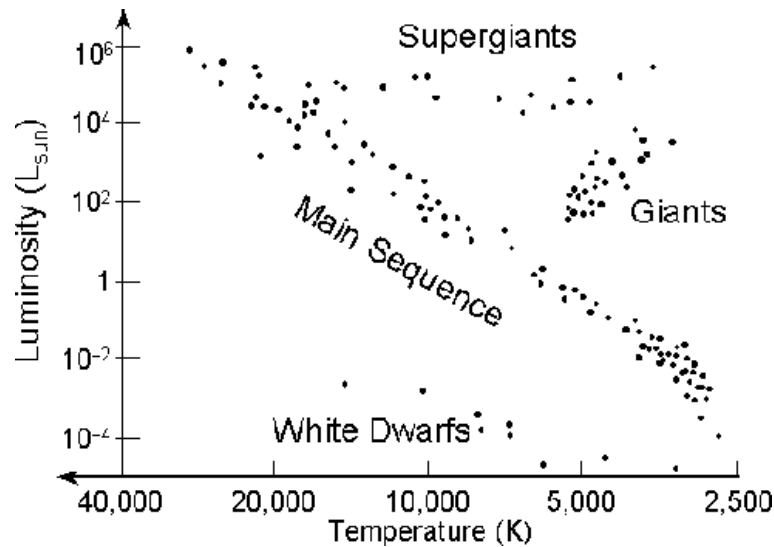

The positions of the various main types of stars are labeled in this HR diagram. The Sun has a temperature of 5,800 K, and a luminosity of 1 L_{Sun} . The Sun is a main sequence “G” star. All stars cooler than the Sun are plotted to the right of the Sun in this diagram. Cool main sequence stars (with spectral types of K and M) are plotted to the lower right of the Sun. Hotter main sequence stars (O, B, A, and F stars) are plotted to the upper left of the Sun’s position. As the Sun runs out of hydrogen fuel in its center, it will become a red giant star—a star that is cooler than the Sun, but $100\times$ more luminous. Red giants are plotted to the upper right of the Sun’s position. As the Sun runs out of all of its fuel, it sheds its atmosphere and ends its days as a white dwarf. White dwarfs are hotter, and much less luminous than the Sun, so they are plotted to the lower left of the Sun’s position in the HR diagram.

The HR diagrams for clusters can be very different depending on their ages. In the following examples, we show the HR diagram of a hypothetical cluster of stars at a variety of different ages. When the star cluster is very young, (see Fig. 6.1) only the hottest stars have

made it to the main sequence. In the HR diagram below, the G, K, and M stars (stars that have temperatures below 6,000 K) are still not on the main sequence, while those stars hotter than 7,000 K (O, B, A, and F stars) are already fusing hydrogen into helium at their cores:

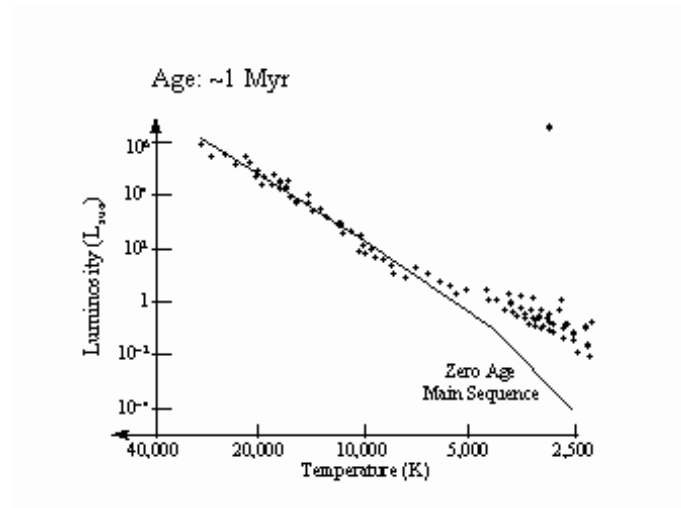

Figure 6.1: The HR diagram of a cluster of stars that is 1 million years old.

In the next HR diagram, Figure 6.2, we see a much older cluster of stars (100 million years = 100 Myr). In this older cluster, some of the hottest and most massive stars (the O and B stars) have evolved into red supergiants. The position of the “main sequence turn off” allows us to estimate the age of a cluster.

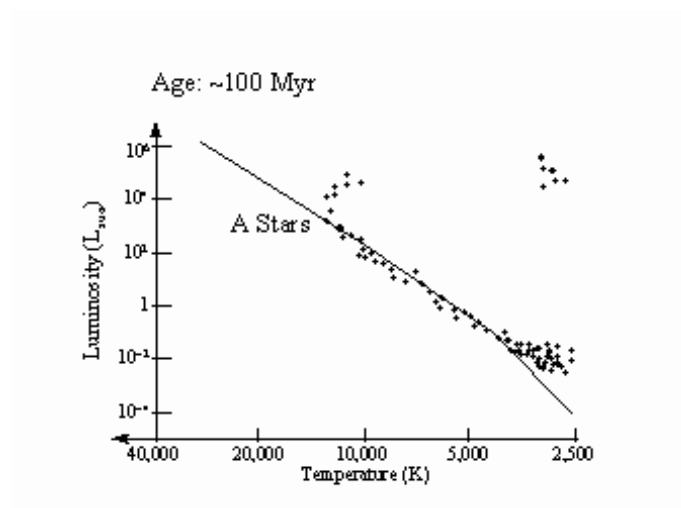

Figure 6.2: The HR diagram of a cluster of stars that is 100 million years old.

In the final HR diagram, Figure 6.3, we have a much older cluster (10 billion years old = 10 Gyr), now stars with one solar mass are becoming red giants, and we say the main

sequence turn-off is at spectral type G ($T = 5,500$ K).

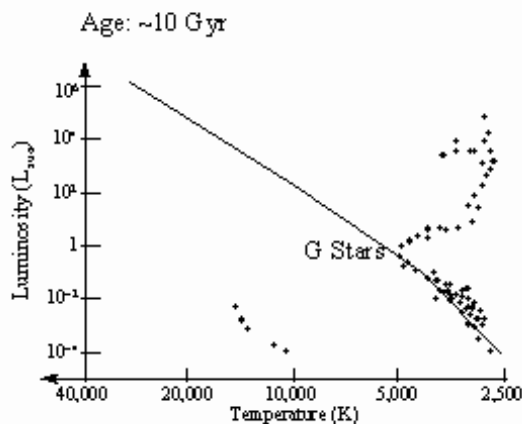

Figure 6.3: The HR diagram of a cluster of stars that is 10 billion years old.

Some white dwarfs (produced by evolved A and F stars) now exist in the cluster. Thus, the HR diagram for a cluster of stars is useful for determining its age.

6.2 Magnitudes and Color Index

While the HR diagrams presented in your class lectures or textbook allow us to provide a very nice description of the evolution of stars and star clusters, astronomers do not actually directly measure either the temperatures or luminosities of stars. Remember that luminosity is a measure the total amount of energy that a star emits. For the Sun it is 10^{26} Watts. But how much energy appears to be coming from an object depends on how far away that object is. Thus, to determine a star's luminosity requires you to know its distance. For example, the two brightest stars in the constellation Orion (see the "Constellation Highlight" for February from the Ast110 homepage link), the red supergiant Betelgeuse and the blue supergiant Rigel, appear to have about the same brightness. But Rigel is six more times luminous than Betelgeuse—Rigel just happens to be further away, so it appears to have the same brightness even though it is pumping out much more energy than Betelgeuse. The "Dog star" Sirius, located to the southeast of Orion, is the brightest star in the sky and appears to be about 5 times brighter than either Betelgeuse or Rigel. But in fact, Sirius is a nearby star, and actually only emits $22\times$ the luminosity of the Sun, or about $1/2000^{\text{th}}$ the luminosity of Rigel!

Therefore, without a distance, it is impossible to determine a star's luminosity—and remember that it is very difficult to measure the distance to a star. We can, however, measure the relative luminosity of two (or more) stars if they are at the same distance: for example if they are both in a cluster of stars. If two stars are at the same distance, then the difference in their apparent brightness is a measurement of the true differences in their luminosities. To

measure the apparent brightness of a star, astronomers use the ancient unit of “magnitude”. This system was first developed by the Greek astronomer Hipparchos (*ca.* 190 to 120 BC). Hipparchos called the brightest stars “stars of the first magnitude”. The next brightest were called “stars of the second magnitude”. His system progressed all the way down to “stars of the sixth magnitude”, the faintest stars you can see with the naked eye from a dark location.

Astronomers adopted this system and made it more rigorous by defining a five magnitude difference to be exactly equal to a factor of 100 in brightness. That is, a first magnitude star is 100X brighter than a sixth magnitude star. If you are good with mathematics, you will find that a difference of one magnitude turns out to be a factor of 2.5 ($2.5 \times 2.5 \times 2.5 \times 2.5 \times 2.5 = 100$, we say that the fifth root of $100 = 100^{1/5} = 2.5$). Besides this peculiar step size, it is also important to note that the magnitude system is upside down: usually when we talk about something being bigger, faster, or heavier, the quantity being measured increases with size (a car going 100 mph is going faster than one going 50 mph, etc.). In the magnitude system, the brighter the object, the smaller its magnitude! For example, Rigel has an apparent magnitude of 0.2, while the star Sirius (which appears to be 4.5 times brighter than Rigel) has a magnitude of -1.43 .

Even though they are a bit screwy, and cause much confusion among Astronomy 110 students, astronomers use magnitudes because of their long history and tradition. So, when astronomers measure the brightness of a star, they measure its apparent magnitude. How bright that star appears to be on the magnitude scale. Usually, astronomers will measure the brightness of a star in a variety of different color filters to allow them to determine its temperature. This technique, called “multi-wavelength photometry”, is simply the measurement of how much light is detected on Earth at a specific set of wavelengths from a star of interest. Most astronomers use a system of five filters, one each for the ultraviolet region (the “U filter”), the blue region (the “B filter”), the visual (“V”, or green) region, the yellow-red region (“R”), and the near-infrared region (“I”). Generally, when doing real research, astronomers measure the apparent magnitude of a star in more than one filter. [Note: because the name of the filter can some times get confused with spectral types, filter names will be *italicized* to eliminate any possible confusion.]

To determine the temperature of a star, measurements of the apparent brightness in at least two filters is necessary. The difference between these two measurements is called the “color index”. For example, the apparent magnitude in the *B* filter minus the apparent magnitude in the *V* filter, $(B - V)$, is one example of a color index (it is also the main color index used by astronomers to measure the temperature of stars, but any two of the standard filters can be used to construct a color index). Let us take Polaris (the “North Star”) as an example. Its apparent *B* magnitude is 2.59, and its apparent *V* magnitude is 2.00, so the color index for Polaris is $(B - V) = 2.59 - 2.00 = 0.59$. In Table 6.1, we list the $(B - V)$ color index for main sequence stars. We see that Polaris has the color of a G star.

In Table 6.1, we see that O and B stars have negative $(B - V)$ color indices. We say that O and B stars are “Blue”, because they emit more light in the *B* filter than in the *V* filter. We say that K and M stars are very red, as they emit much more *V* light than *B*

Table 6.1: The $(B - V)$ Color Index for Main Sequence Stars

Spectra Type	$(B - V)$	Spectral Type	$(B - V)$
O and B Stars	-0.40 to -0.06	G Stars	0.59 to 0.76
A Stars	0.00 to 0.20	K Stars	0.82 to 1.32
F Stars	0.31 to 0.54	M Stars	1.41 to 2.00

light (and even more light in the R and I filters!). A-stars emit the same amount of light at B and V , while F and G stars emit slightly more light at V than at B . With this type of information, we can now figure out the spectral types, and hence temperatures of stars by using photometry.

6.3 The Color-Magnitude HR Diagram

To construct HR diagrams of star clusters, astronomers measure the apparent brightness of stars in two different color filters, and then plot the data into a “Color-Magnitude” diagram, plotting the apparent V magnitude versus the color index $(B - V)$ as shown below. Figure 6.4 shows a color-magnitude diagram for a globular cluster. You might remember from class (or will soon be told!) that globular clusters are old, and that the low mass stars are evolving off the main sequence and becoming red giants. The main sequence turnoff for this globular cluster is at a color index of about $(B - V) = 0.4$, the color of F stars. An F star has a mass of about $1.5 M_{\text{Sun}}$, thus stars with masses near $1.5 M_{\text{Sun}}$ are evolving off the main sequence to become red giants, so this globular cluster is about 7 billion years old.

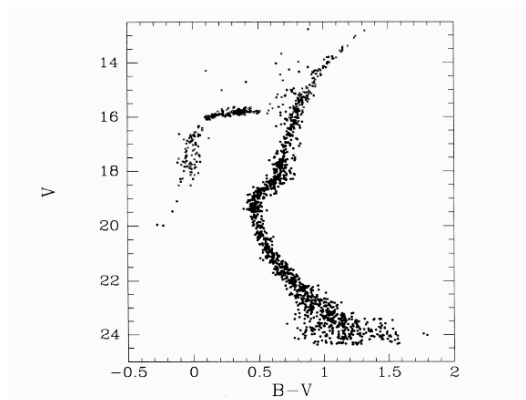

Figure 6.4: The HR diagram for the globular cluster M15.

6.4 The Color-Magnitude Diagram for the Pleiades

In today’s lab, you and your lab partners will construct a color magnitude diagram for the Pleiades star cluster. The Pleiades, sometimes known as the “Seven Sisters” (see the constellation highlight for January at the back of this lab manual), is a star cluster located in

the wintertime constellation of Taurus, and can be seen with the naked eye. A wide-angle photograph of the Pleiades is shown below (Fig. 6.4). Many people confuse the Pleiades with the Little Dipper because the brightest stars form a small dipper-like shape.

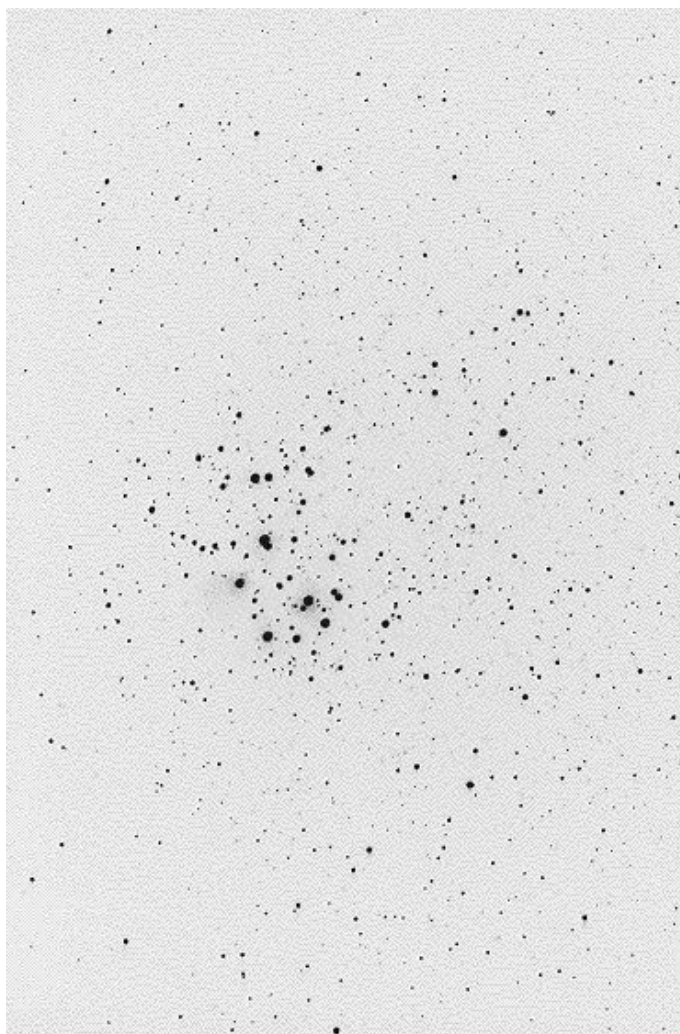
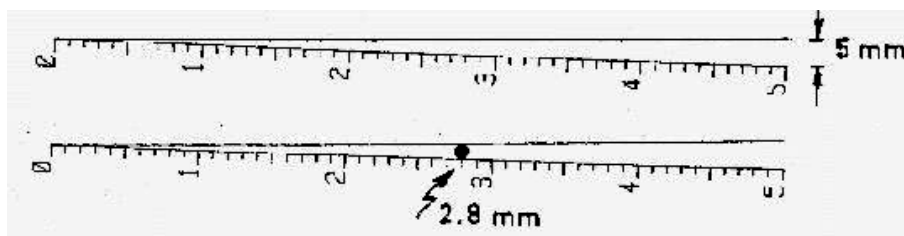

Figure 6.5: A photograph of the Pleiades.

As you will find out, the Pleiades is a relatively young group of stars. We will be using photographs of the Pleiades taken using two different color filters to construct a Color-Magnitude diagram. If you look closely at the photograph of the Pleiades, you will notice that the brighter stars are larger in size than the fainter stars. Note: you are not seeing the actual disks of the stars in these photographs. Brighter stars appear bigger on photographs because more light from them is detected by the photograph. As the light from the stars accumulates, it spreads out. Think of a pile of sand. As you add sand to a pile, it develops a conical, pyramid shape. The addition of more sand to the pile raises the height of the sand pile, but the *base* of the sand pile has to spread more to support this height. The same thing happens on a photograph. The more light there is, the larger the spread in the *image* of the

star. In reality, *all* of the stars in the sky are much too far away to be seen as little disks (like those we see for the planets in our solar system) when viewed/imaged through *any existing telescope*. We would need to have a space-based telescope with a mirror 1.5 miles across to actually be able to see the stars in the Pleiades as little, resolved disks! [However, there are some special techniques astronomers have developed to actually measure the diameters of stars. Ask your TA about them if you are curious.]

Thus, we can use the sizes of the stars on a photograph to figure out how bright they are, we simply have to measure their diameters! A special tool, called a “dynamometer”, is used to measure sizes of circles. You will be given a clear plastic dynamometer in class. A replica of this dynamometer is shown here:



As demonstrated, a dynamometer allows you to measure the diameter of a star image by simply sliding the dynamometer along until the edges of the star just touch the lines. In the example above, the star image is 2.8 mm in diameter. On the following two pages are digitized scans of two photographs of the Pleiades taken through *B* and *V* filters. These photographs were digitized to allow us to put in an X-Y scale so that you can keep track of which star is which in the two different photographs. You should be able to compare the digitized photographs with the actual photo shown above and see that most of the brighter stars are on all three images.

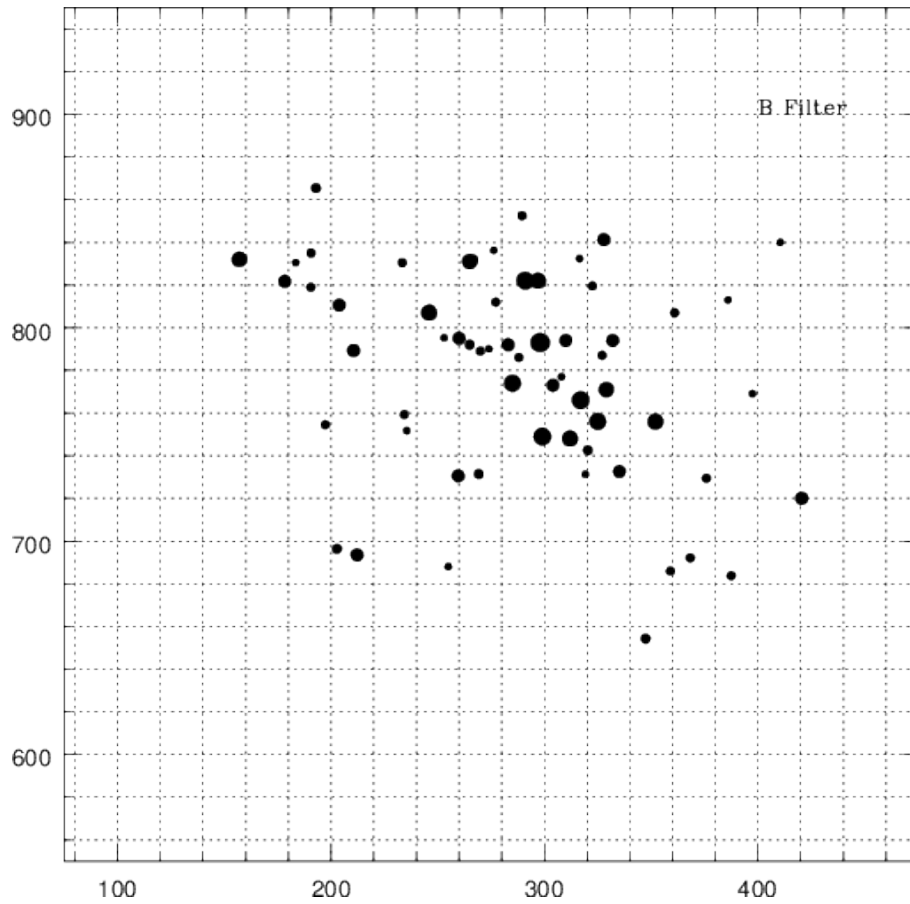

Figure 6.6: This is not the right figure for use in this lab—your TA will give you the correctly scaled version. (Go to: <http://astronomy.nmsu.edu/astro/hrlabB.ps>)

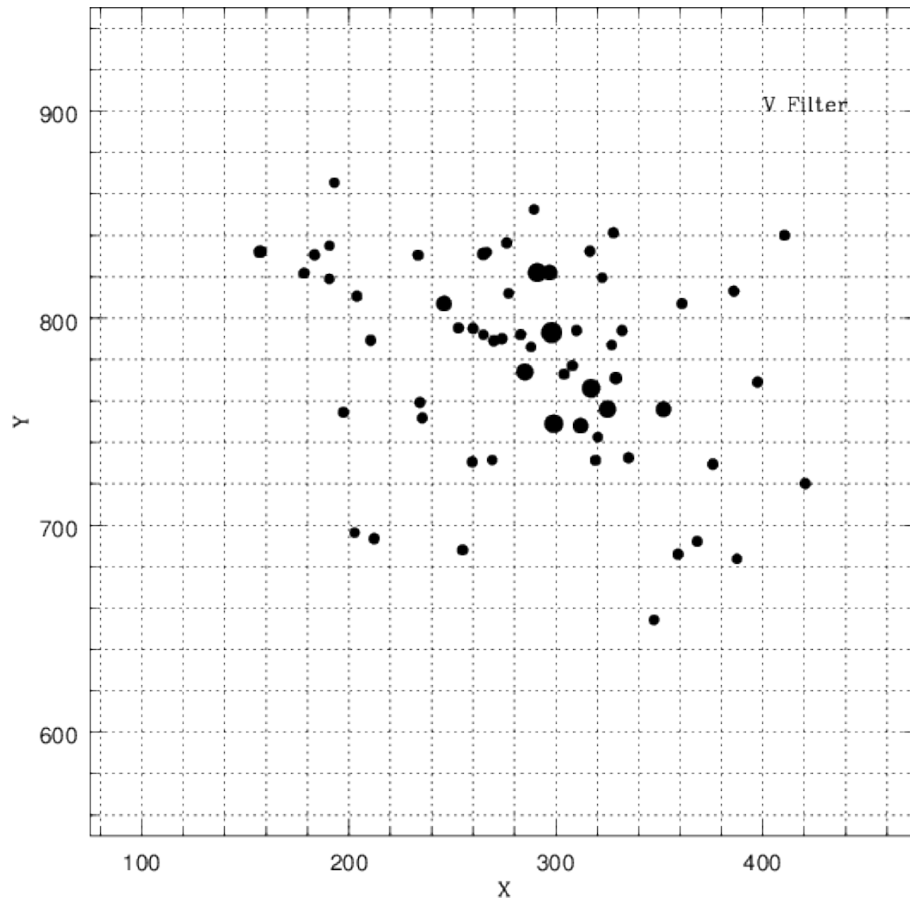

Figure 6.7: This is not the right figure for use in this lab—your TA will give you the correctly scaled version. (Go to: <http://astronomy.nmsu.edu/astro/hrlabB.ps>)

6.4.1 Procedure

The first task for this lab is to collect your data. What you need to do for this lab is to measure the diameters of ten of the 63 stars on both digitized photographs. At the end of this lab there is a data table that has the final data for 53 of the 63 stars. It is missing the information for ten of the stars (#'s 7, 8, 13, 18, 30, 39, 53, 55, 61, and 63). You must collect the data for these ten stars.

Task #1: First, identify the stars with the missing data on *both* of the digitized photographs (use their X,Y positions to do this). Then measure their diameters of these ten stars on both photographs using the dynameter. Write the V and B diameters into the appropriate spaces within the data table. [Note: You will probably not be able to measure the diameters to the same precision as shown for the other stars in the data table. Those diameters were measured using a computer. Do the best you can—make several measurements of each star and average the results.] **(15 points)**

6.4.2 Converting Diameters to Magnitudes

Obviously, the diameter you measure of a star on a photograph has no obvious link to its actual magnitude. For example, we could blow the photograph up, or shrink it down. The diameters of the stars would change, but the relative change in size between stars of different brightnesses would stay the same. To turn diameters into magnitudes requires us to “calibrate” the two photographs. For example, the brightest star in the Pleiades, “Alcyone” (star #35), has a V magnitude of 2.92, and has a V diameter of 4.4 mm. We have used this star to calibrate our data. Once you have completed measuring the diameters of the stars, you must convert those diameters (in millimeters) into V magnitudes and $(B - V)$ color index. To do so, requires you to use the following two equations:

$$V(\text{mag}) = -2.95 \times (V \text{ mm}) + 15.9 \text{ (Eq. \# 1)}$$

and

$$(B - V) = -1.0 \times (B \text{ mm} - V \text{ mm}) + 0.1 \text{ (Eq. \#2)}$$

These equations might seem confusing to you because of the negative number in front of the diameters. But if you remember, the brighter the star, the smaller its magnitude. Brighter stars appear bigger, so bigger diameters mean smaller magnitudes! That is why there is a negative sign. Using the example of Alcyone, its V diameter is 4.4 mm and it has a B diameter of 4.7 mm. Putting the V diameter into equation #1 gives: $V(\text{mag}) = -2.95 \times (4.4 \text{ mm}) + 15.9 = -13.0 + 15.9 = 2.9$. So, the V magnitude of Alcyone is correct: $V = 2.9$, and we have calibrated the photograph. Its color index can be found using Eq. #2: $(B - V) = -1.0 \times (4.7 - 4.4) + 0.1 = -1.0 \times (0.4) + 0.1 = -0.20$. Alcyone is a B star!

Task #2: Convert all of the B and V diameters into V magnitudes and $(B - V)$ color index, entering them into the proper column in your data table. Use any of the other stars in the table to see how it is done. Make sure all students in your group have complete tables with all of the data entered. **(15 points)**

6.4.3 Constructing a Color-Magnitude Diagram

The collection of the data is now complete. In this lab you are getting exactly the same kind of experience in “reducing data” that real astronomers do. Aren’t you glad you didn’t have to measure the diameters of all 63 stars? Obtaining and reducing data can be very tedious, tiring, or even boring. But it is an essential part of the scientific process. Because of the possibility of mis-measurement of the star diameters, a real astronomer doing this lab would probably measure all of the star diameters at least three times to insure that they had not made any errors. Today, we will assume you did everything exactly right, but we will provide a check shortly.

Now we want to finally get to the goal of the lab: constructing a Color-Magnitude diagram. In this portion of the lab, we will be plotting the V magnitudes vs. the $(B - V)$ color index. On the following page is a blank grid that has V magnitude on the Y axis, and the $(B - V)$ color index on the X axis. Now we want to plot your data onto this blank Color-Magnitude diagram to closely examine what kind of stars are in the Pleiades.

Task #3: For each star in your table, plot its position where the $(B - V)$ color index is the X coordinate, and the V magnitude is the Y coordinate. Note that some stars will have very similar magnitudes and colors because they are the same types of star. When this happens, simply plot them as close together as possible, making sure they are slightly separated for clarity. All students must complete their own Color-Magnitude diagram. **(15 points)**

Error checking: All of your stars should fit within the boundaries of the Color-Magnitude diagram! If not, go back and re-measure the problem star(s) to see if you have made an error in the B or V diameter or in the calculations.

6.5 Results

If you have done everything correctly, you should now have a Color-Magnitude diagram in which your plotted stars trace out the main sequence for the Pleiades. Use your Color-Magnitude diagram to answer the following questions:

1. Are there more B stars in the Pleiades, or more K stars? **(5 points)**

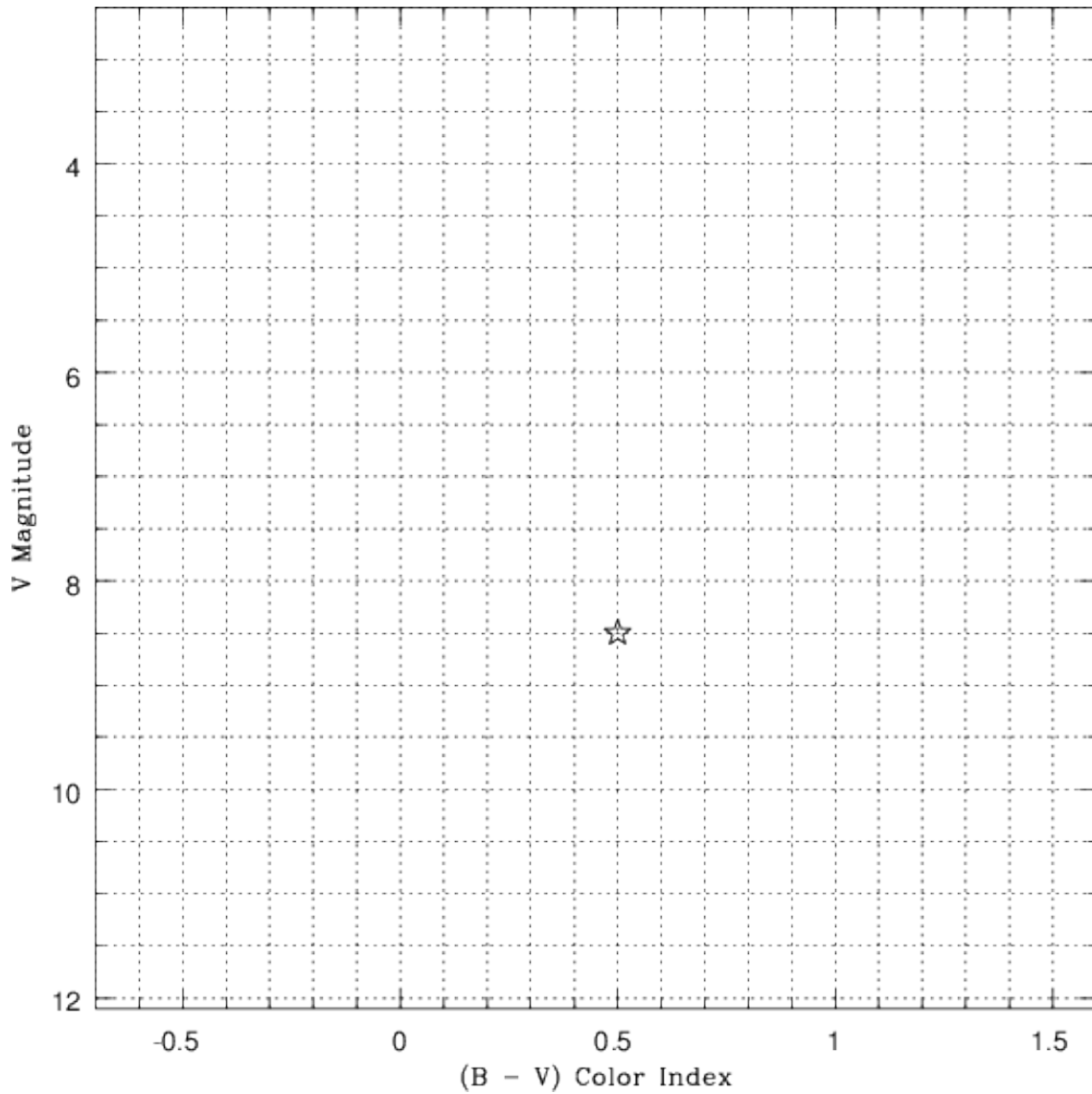

Figure 6.8: The Color-Magnitude Diagram for the Pleiades

2. Given that the Sun is a main sequence G star, draw an “X” to mark the spot where the Sun would be in your Color-Magnitude diagram for the Pleiades (**5 points**)

3. The faintest stars that the human eye can see on a clear, dark night is $V = 6.0$. If the Sun was located in the Pleiades, could you see it with the naked eye? (**5 points**)

4. Are there any red giants or supergiants in the Pleiades? What does this tell you about the age of the Pleiades? (**5 points**)

6.6 Summary (35 points)

Please summarize the important concepts of this lab.

- Describe how an HR diagram is constructed.
- If you have plotted your HR Diagram for the Pleiades correctly, you will notice that the faint, red stars seem to have a spread when compared to the brighter, bluer stars. Why do you think this occurs? How might you change your observing or measuring procedure to fix this problem? [Hint: is it harder or easier to measure big diameters vs. small diameters?]
- Why are HR diagrams important to astronomers?

Use complete sentences, and proofread your lab before handing it in.

6.7 Possible Quiz Questions

1. What is a magnitude? Which star is brighter, a star with $V = -2.0$, or one with $V = 7.0$?
2. In an HR Diagram, what are the two quantities that are plotted?
3. What are the properties of a white dwarf?
4. What are the properties of a red giant?
5. What is a Color Index, and what does it tell you about a star?

6.8 Extra Credit (ask your TA for permission before attempting, 5 points)

White dwarfs are $100\times$ less luminous than the Sun, but are hot, and have a negative color index $(B - V) = -0.2$. Given that a factor of $100 = 5$ magnitudes, is it possible to plot the positions of white dwarfs on your Color-Magnitude diagram for the Pleiades?

Table 6.2: Data Table

#	X	Y	V(mm)	B(mm)	V(mag)	($B - V$)
01	157.00	832.00	3.10	2.89	6.76	0.31
02	157.61	832.20	2.49	2.00	8.50	0.59
03	178.33	821.70	2.37	1.70	8.91	0.77
04	183.40	830.51	2.32	1.60	9.06	0.82
05	190.53	818.94	2.24	1.52	9.29	0.82
06	190.62	834.99	2.23	1.52	9.32	0.81
07	192.98	865.44				
08	197.37	754.50				
09	202.78	696.35	2.23	1.46	9.32	0.87
10	203.87	810.57	2.36	1.72	8.94	0.74
11	210.57	789.29	2.32	1.62	9.06	0.80
12	212.22	693.49	2.48	1.97	8.58	0.61
13	233.44	830.40				
14	234.34	759.27	2.35	1.57	8.97	0.88
15	235.50	751.74	2.40	1.85	8.82	0.65
16	246.00	807.00	3.26	3.07	6.28	0.29
17	252.95	795.24	2.75	2.35	7.78	0.50
18	254.95	688.02				
19	259.60	730.54	2.39	1.74	8.85	0.75
20	260.00	795.00	2.35	1.77	8.97	0.68
21	265.00	792.00	2.24	1.48	9.29	0.86
22	265.00	831.00	2.95	2.65	7.20	0.40
23	266.66	831.82	2.20	1.36	9.41	0.94
24	269.27	731.47	2.18	1.33	9.47	0.95
25	270.00	789.00	2.31	1.62	9.09	0.79
26	274.00	790.00	2.32	1.70	9.06	0.72
27	276.28	836.35	2.50	1.98	8.53	0.62
28	277.19	811.96	2.22	1.55	9.35	0.77
29	283.00	792.00	2.35	1.75	8.97	0.70
30	285.00	774.00				
31	288.00	786.00	2.20	1.42	9.41	0.88
32	289.50	852.50	2.18	1.54	9.47	0.74
33	291.00	822.00	4.24	4.46	3.39	-0.12
34	297.00	822.00	3.46	3.38	5.69	0.18
35	298.00	793.00	4.40	4.70	2.92	-0.20
36	299.00	749.00	4.09	4.23	3.83	-0.04
37	304.00	773.00	2.39	1.79	8.85	0.70
38	308.00	777.00	2.31	1.67	9.09	0.74
39	310.00	794.04				
40	312.00	748.00	3.35	3.20	6.02	0.25

Table 6.3: Data Table (cont.)

#	X	Y	V(mm)	B(mm)	V(mag)	($B - V$)
41	316.46	832.35	2.52	2.01	8.47	0.61
42	317.00	766.00	3.93	4.00	4.31	0.03
43	319.14	731.31	2.38	1.81	8.88	0.67
44	320.29	742.55	2.17	1.46	9.50	0.81
45	322.43	819.50	2.17	1.52	9.50	0.75
46	325.00	756.00	3.62	3.57	5.22	0.15
47	327.00	787.00	2.20	1.47	9.41	0.83
48	327.80	841.25	2.34	1.68	8.99	0.76
49	329.00	771.00	2.87	2.52	7.43	0.45
50	332.00	794.00	2.62	2.14	8.17	0.58
51	335.13	732.56	2.28	1.54	9.17	0.84
52	347.41	654.23	2.15	1.43	9.55	0.82
53	352.00	756.00				
54	359.05	685.95	2.35	1.70	8.97	0.75
55	361.00	807.00				
56	368.31	692.12	2.35	1.69	8.96	0.76
57	375.90	729.41	2.20	1.50	9.41	0.80
58	375.90	729.41	2.36	1.73	8.94	0.73
59	386.00	813.00	2.37	1.72	8.91	0.75
60	387.50	683.69	2.20	1.54	9.41	0.76
61	397.48	769.11				
62	410.49	839.98	2.34	1.62	8.99	0.82
63	420.52	720.04				

Name: _____

Date: _____

7 Our Sun

7.1 Introduction

The Sun is a very important object for all life on Earth. The nuclear reactions which occur in its core produce the energy which plants and animals need to survive. We schedule our lives around the rising and setting of the Sun in the sky. During the summer, the Sun is higher in the sky and thus warms us more than during the winter, when the Sun stays low in the sky. But the Sun's effect on Earth is even more complicated than these simple examples.

The Sun is the nearest star to us, which is both an advantage and a disadvantage for astronomers who study stars. Since the Sun is very close, and very bright, we know much more about the Sun than we know about other distant stars. This complicates the picture quite a bit since we need to better understand the physics going in the Sun in order to comprehend all our detailed observations. This difference makes the job of solar astronomers in some ways more difficult than the job of stellar astronomers, and in some ways easier! It's a case of having lots of incredibly detailed data. But all of the phenomena associated with the Sun are occurring on other stars, so understanding the Sun's behavior provides insights to how other stars might behave.

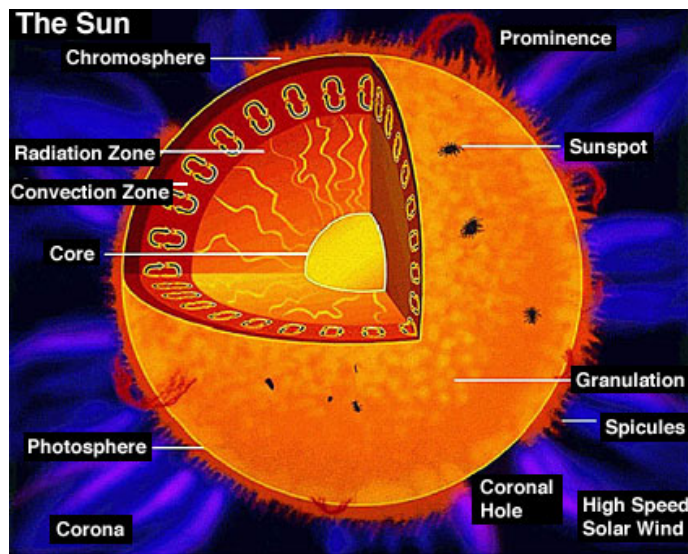

Figure 7.1: A diagram of the various layers/components of the Sun, as well as the appearance and location of other prominent solar features.

- *Goals:* to discuss the layers of the Sun and solar phenomena; to use these concepts

in conjunction with pictures to deduce characteristics of solar flares, prominences, sunspots, and solar rotation

- *Materials:* You will be given a Sun image notebook, a bar magnet with iron filings and a plastic tray. You will need paper to write on, a ruler, and a calculator

7.2 Layers of the Sun

One of the things we know best about the Sun is its overall structure. Figure 7.1 is a schematic of the layers of the Sun's interior and atmosphere. The interior of the Sun is made up of three distinct regions: the core, the radiative zone, and the convective zone. The *core* of the Sun is very hot and dense. This is the only place in the Sun where the temperature and pressure are high enough to support nuclear reactions. The *radiative zone* is the region of the sun where the energy is transported through the process of radiation. Basically, the photons generated by the core are absorbed and emitted by the atoms found in the radiative zone like cars in stop and go traffic. This is a very slow process. The *convective zone* is the region of the Sun where energy is transported by rising "bubbles" of material. This is the same phenomenon that takes place when you boil a pot of water. The hot bubbles rise to the top, cool, and fall back down. This gives the the surface of the Sun a granular look. Granules are bright regions surrounded by darker narrow regions. These granules cover the entire surface of the Sun.

The atmosphere of the Sun is also comprised of three layers: the photosphere, the chromosphere, and the corona. The *photosphere* is a thin layer that forms the visible surface of the Sun. This layer acts as a kind of insulation, and helps the Sun retain some of its heat and slow its consumption of fuel in the core. The *chromosphere* is the Sun's lower atmosphere. This layer can only be seen during a solar eclipse since the photosphere is so bright. The *corona* is the outer atmosphere of the Sun. It is very hot, but has a very low density, so this layer can only be seen during a solar eclipse (or using specialized telescopes). More information on the layers of the Sun can be found in your textbook.

7.3 Sunspots

Sunspots appear as dark spots on the photosphere (surface) of the Sun (see Figure 7.2). They last from a few days to over a month. Their average size is about the size of the Earth, although some can grow to many times the size of the Earth! Sunspots are commonly found in pairs. How do these spots form?

The formation of sunspots is attributed to the Sun's *differential rotation*. The Sun is a ball of gas, and therefore does not rotate like the Earth, or any other solid object. The Sun's equator rotates faster than its poles. It takes roughly 25 days for material to travel once around the equator, but about 35 days for it to travel once around near the north or south poles. This differential rotation acts to twist up the magnetic field lines inside the Sun. At times, the lines can get so twisted that they pop out of the photosphere. Figure 7.3

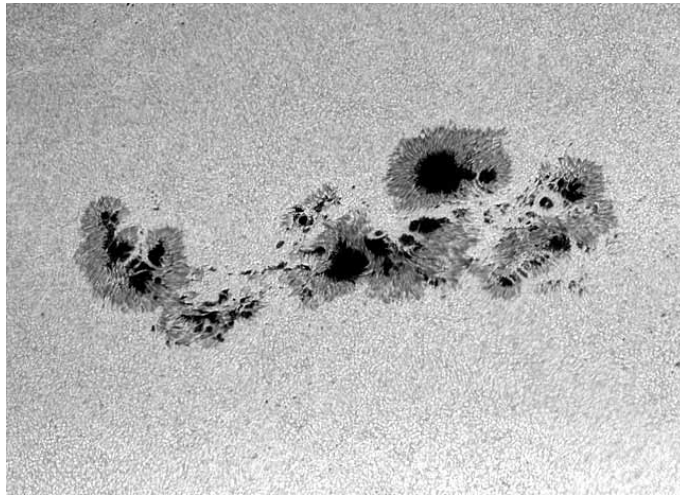

Figure 7.2: A large group of Sunspots. The “umbra” is the darker core of a sunspot, while the “penumbra” is its lighter, frilly edges.

illustrates this concept. When a magnetic field loop pops out, the places where it leaves and re-enters the photosphere are cooler than the rest of the Sun’s surface. These cool places appear darker, and therefore are called “sunspots”.

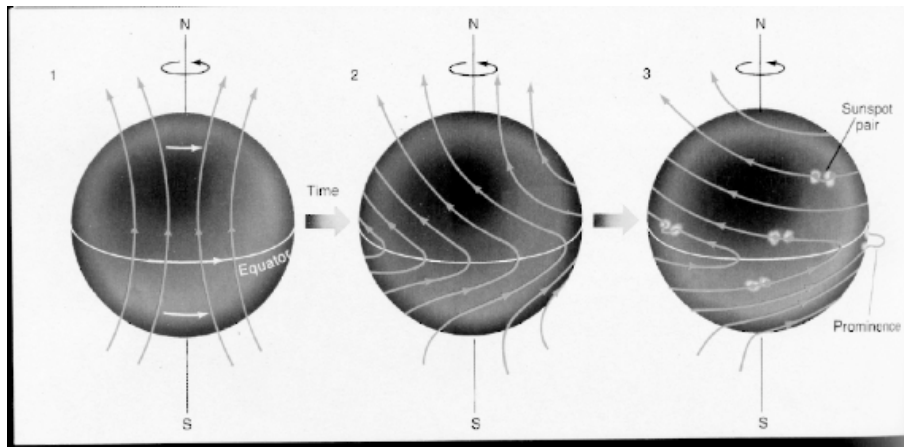

Figure 7.3: Sunspots are a result of the Sun’s differential rotation.

The number of sunspots rises and falls over an 11 year period. This is the amount of time it takes for the magnetic lines to tangle up and then become untangled again. This is called the *Solar Cycle*. Look in your textbook for more information on sunspots and the solar cycle.

7.4 Solar Phenomenon

The Sun is a very exciting place. All sorts of activity and eruptions take place in it and around it. We will now briefly discuss a few of these interesting phenomena. You will be

analyzing pictures of prominences during this lab.

Prominences are huge loops of glowing gas protruding from the chromosphere. Charged particles spiral around the magnetic field lines that loop out over the surface of the Sun, and therefore we see bright loops above the Sun's surface. Very energetic prominences can break free from the magnetic field lines and shoot out into space.

Flares are brief but bright eruptions of hot gas in the Sun's atmosphere. These eruptions occur near sunspot groups and are associated with the Sun's intertwined magnetic field lines. A large flare can release as much energy as 10 billion megatons of TNT! The charged particles that flares emit can disrupt communication systems here on Earth.

Another result of charged particles bombarding the Earth is the Northern Lights. When the particles reach the Earth, they latch on to the Earth's magnetic field lines. These lines enter the Earth's atmosphere near the poles. The charged particles from the Sun then excite the molecules in Earth's atmosphere and cause them to glow. Your textbook will have more fascinating information about these solar phenomena.

7.5 Lab Exercises

There are three main exercises in this lab. The first part consists of a series of "stations" in a three ring binder where you examine some pictures of the Sun and answer some questions about the images that you see. Use the information that you have learned from lectures and your book to give explanations for the different phenomena that you see at each station. In the second exercise you will learn about magnetic fields using a bar magnet and some iron filings. Finally, for those labs that occur during daylight hours (i.e., starting before 5 pm!), you will actually look at the Sun using a special telescope to see some of the phenomena that were detailed in the images in the first exercise of this lab (for those students in night-time labs, arrangements might be made so as to observe the Sun during one of your lecture sessions). During this lab you will use your own insight and knowledge of basic physics and astronomy to obtain important information about the phenomena that we see on the Sun, just as solar astronomers do. As with all of the other exercises in this lab manual, if there is not sufficient room to write in your answers into this lab, do not hesitate to use additional sheets of paper. Do not try to squeeze your answers into the tiny blank spaces in this lab description if you need more space than provided! Don't forget to **SHOW ALL OF YOUR WORK**.

One note of caution about the images that you see: the colors of the pictures (especially those taken by SOHO) are *not* true colors, but are simply colors used by the observatories' image processing teams to best enhance the features shown in the image.

7.5.1 Exercise #1: Getting familiar with the Size and Appearance of the Sun

Station 1: In this first station we simply present some images of the Sun to familiarize yourself with what you will be seeing during the remainder of this lab. Note that this station has no questions that you have to answer, but you still should take time to familiarize yourself with the various features visible on/near the Sun, and get comfortable with the specialized, filtered image shown here.

- The first image in this station is a simple “white light” picture of the Sun as it would appear to you if you were to look at it in a telescope that was designed for viewing the Sun. Note the dark spots on the surface of the Sun. These are “sunspots”, and are dark because they are cooler than the rest of the photosphere.
- When we take a very close-up view of the Sun’s photosphere we see that it is broken up into much smaller “cells”. This is the “solar granulation”, and is shown in picture #2. Note the size of these granules. These convection cells are about the size of New Mexico!
- To explore what is happening on the Sun more fully requires special tools. If you have had the spectroscopy lab, you will have seen the spectral lines of elements. By choosing the right element, we can actually probe different regions in the Sun’s atmosphere. In our first example, we look at the Sun in the light of the hydrogen atom (“H-alpha”). This is the red line in the spectrum of hydrogen. If you have a daytime lab, and the weather is good, you will get to see the Sun just like it appears in picture #3. The dark regions in this image is where cool gas is present (the dark spot at the center is a sunspot). The dark linear, and curved features are “prominences”, and are due to gas caught in the magnetic field lines of the underlying sunspots. They are above the surface of the Sun, so they are a little bit cooler than the photosphere, and therefore darker.
- Picture #4 shows a “loop” prominence located at the edge (or “limb”) of the Sun (the disk of the Sun has been blocked out using a special telescope called a “coronagraph” to allow us to see activity near its limb). If the Sun cooperates, you may be able to see several of these prominences with the solar telescope. You will be returning to this image in Exercise #2.

Station 2: Here are two images of the Sun taken by the SOHO satellite several days apart (the exact times are at the top of the image). **(8 points)**

- Look at the sunspot group just below center of the Sun in **image 1**, and then note that it has rotated to the western (right-hand) limb of the Sun in **image 2**. Since the sunspot group has moved from center to limb, you then know that the Sun has rotated by one quarter of a turn (90°).
- Determine the precise time difference between the images. Use this information plus the fact that the Sun has turned by 90 degrees in that time to determine the rotation

rate of the Sun. If the Sun turns by 90 degrees in time t , it would complete one revolution of 360 degrees in how much time?

- Does this match the rotation rate given in your textbook or in lecture? Show your work.

In the second photograph of this station are two different images of the Sun: the one on the left is a photo of the Sun taken in the near-infrared at Kitt Peak National Observatory, and the one on the right is a “magnetogram” (a picture of the magnetic field distribution on the surface of the Sun) taken at about the same time. (Note that black and white areas represent regions with different *polarities*, like the north and south poles of the bar magnet used in the second part of this lab.) **(7 points)**

- What do you notice about the location of *sunspots* in the photo and the location of the *strongest magnetic fields*, shown by the brightest or darkest colors in the magnetogram?

- Based on this answer, what do you think causes sunspots to form? Why are they dark?

Station 3: Here is a picture of the *corona* of the Sun, taken by the SOHO satellite in the extreme ultraviolet. (An image of the Sun has been superimposed at the center of the

picture. The black ring surrounding it is a result of image processing and is not real.) **(10 points)**

- Determine the diameter of the Sun, then measure the minimum extent of the corona (diagonally from upper left to lower right).
- If the photospheric diameter of the Sun is 1.4 million kilometers (1.4×10^6 km), how big is the corona? (HINT: use unit conversion!)
- How many times larger than the Earth is the corona? (Earth diameter=12,500 km)

Station 4: This image shows a time-series of exposures by the SOHO satellite showing an *eruptive prominence*. **(15 points)**

- As in station 3, measure the diameter of the Sun and then measure the distance of the top of the prominence from the edge of the Sun in the first (earliest) image. Then measure the distance of the top of the prominence from the edge of the Sun in the last image.

- Convert these values into real distances based on the linear scale of the images. Remember the diameter of the Sun is 1.4×10^6 kilometers.
- The velocity of an object is the distance it travels in a certain amount of time ($\text{vel}=\text{dist}/\text{time}$). Find the velocity of the prominence by subtracting the two distances and dividing the answer by the amount of time between the two images.
- In the most severe of solar storms, those that cause flares, and “coronal mass ejections” (and can disrupt communications on Earth), the material ejected in the prominence (or flare) can reach velocities of 2,000 kilometers per second. If the Earth is 150×10^6 kilometers from the Sun, how long (hours or days) would it take for this ejected material to reach the Earth?

Station 5: This is a plot of where sunspots tend to occur on the Sun as a function of *latitude* (top plot) and time (bottom plot). What do you notice about the distribution sunspots? How long does it take the pattern to repeat? What does this length of time correspond to? **(3 points)**

7.5.2 Exercise #2: Exploring Magnetic Fields

The magnetic field of the Sun drives most of the solar activity. In this subsection we compare the magnetic field of sunspots to that of a bar magnet. During this exercise you will be using a plastic tray in which you will sprinkle iron filings (small bits of iron) to trace the magnetic field of a bar magnet. This can be messy, so be careful as we only have a finite supply of these iron filings, and the other lab subsections will need to re-use the ones supplied to you.

- First, let's explore the behavior of a compass in the presence of a magnetic field. Grab the bar magnet and wave the "north pole" (the red end of the bar magnet with the large "N") of the magnet by the compass. Which end of the compass needle (or arrow) seems to be attracted by the north pole of the magnet? **(1 point)**

- Ok, reverse the bar magnet so the south pole (white end) is the one closest to the compass. Which end of the compass needle is attracted to the south pole of the bar magnet? **(1 point)**

- The compass needle itself is a little magnet, and the pointy, arrow end of the compass needle is the north pole of this little magnet. Knowing this, what does this say about magnets? Which pole is attracted to which pole (and vice versa)? **(1 point)**

- As you know, a compass can be used to find your way if you are lost because the needle always points towards the North Pole of the Earth. The Earth has its own magnetic field generated deep in its molten iron core. This field acts just like that of a bar magnet. But given your answer to the last question, and the fact that the "north pole" of the compass needle points to the North Pole of the Earth, what is the actual "polarity" of the Earth's "magnetic North" pole? **(1 point)**

We have just demonstrated the power of attraction of a magnetic field. What does a magnetic field look like? In this subsection we use some iron filings, a plastic tray, and the bar

magnet to explore the appearance of a magnetic field, and compare that to what we see on the Sun.

- Place the bar magnet on the table, and center the plastic tray on top of the bar magnet. Gently sprinkle the iron filings on to the plastic tray so that a thin coating covers the entire tray. Sketch the pattern traced-out by the magnetic filings below, and describe this pattern. **(2 points)**

- The iron filings trace the magnetic field lines of the bar magnet. The field lines surround the magnet in all dimensions (though we can only easily show them in two dimensions). Your TA will show you a device that has a bar magnet inside a plastic case to demonstrate the three dimensional nature of the field. Compare the pattern of the iron filings around the bar magnet to the picture of the sunspot shown in Figure 7.4. They are similar! What does this imply about sunspots? **(3 points)**

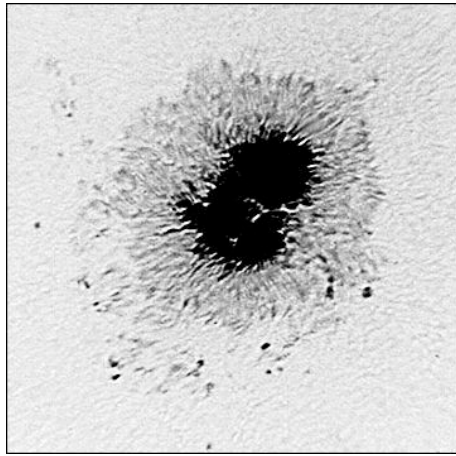

Figure 7.4: The darker region of this double sunspot is called the “umbra”, while the less dark, filamentary region is called the “penumbra”. For this sunspot, one umbra has a “North polarity”, while the other has a “South polarity”.

- Now, let's imagine what a fully three dimensional magnetic field looks like. The pattern of the iron filings around the bar magnet would also exist into the space *above* the bar magnet, but we cannot suspend the iron filings above the magnet. Complete Figure 7.5 by drawing-in what you imagine the magnetic field lines look like *above* the bar magnet. **(3 points)**

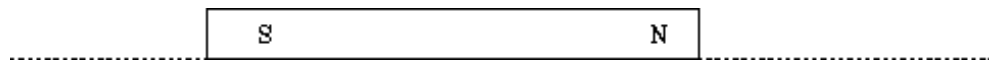

Figure 7.5: Draw in the field lines above this bar magnet.

- Compare your drawing, above, to the image of the loop prominence seen in station #1 of Exercise #1. What are their similarities—imagine if the magnetic field lines emitted light, what would you expect to see? **(2 points)**

If a sunspot pair is like a little bar magnet on the surface of the Sun, the field extends up into the atmosphere, and along the magnetic field charged particles can collect, and we see light emitted by these moving particles (mostly ionized hydrogen). Note that we do not always see the complete set of field lines in prominences because of the lack of material high in the Sun's atmosphere—but the bases of the prominences are visible, and are located just above the sunspot.

*****If the weather is clear, and your TA is ready, you can proceed to Exercise #3 to look at the Sun with a special solar telescope.*****

7.5.3 Exercise #3: Looking at the Sun

The Sun is very bright, and looking at it with either the naked eye or any optical device is dangerous—special precautions are necessary to enable you to actually look at the Sun. To make the viewing safe, we must eliminate 99.999% of the light from the Sun to reduce it to safe levels. In this exercise you will be using a very special telescope designed for viewing the Sun. This telescope is equipped with a hydrogen light filter. It only allows a tiny amount of light through, isolating a single emission line from hydrogen (“H-alpha”). In your lecture session you will learn about the emission spectrum of hydrogen, and in the spectroscopy lab you get to see this red line of hydrogen using a spectroscope. Several of the pictures in Exercise #1 were actually obtained using a similar filter system. This filter system gives us a unique view of the Sun that allows us to better see certain types of solar phenomena, especially the “prominences” you encountered in Exercise #1.

- In the “Solar Observation Worksheet” below, draw what you see on and near the Sun as seen through the special solar telescope. **(8 points)**

Note: Kitt Peak Vacuum Telescope images are courtesy of KPNO/NOAO. SOHO Extreme Ultraviolet Imaging Telescope images courtesy of the SOHO/EIT consortium. SOHO Michelson Doppler Imager images courtesy of the SOHO/MDI consortium. SOHO is a project of international cooperation between the European Space Agency (ESA) and NASA.

Solar Observation Worksheet

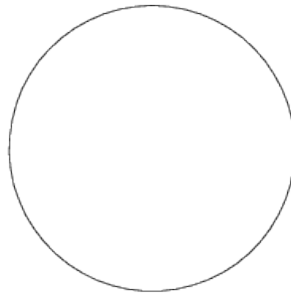

Name: _____

Lab Sec.: _____

Date: _____

TA: _____

7.6 Summary (35 points)

Please summarize the important concepts discussed in this lab.

- Discuss the different types of phenomena and structures you looked at in the lab
- Explain how you can understand what causes a phenomenon to occur by looking at the right kind of data
- List the six layers of the Sun (in order) and give their temperatures.
- What causes the Northern (and Southern) Lights, also known as “Aurorae”?

Use complete sentences and, proofread your summary before turning it in.

Possible Quiz Questions

- 1) What are sunspots, and what leads to their formation?
- 2) Name the three interior regions of the Sun.
- 3) What is differential rotation?
- 4) What is the “photosphere”?
- 5) What are solar flares?

7.7 Extra Credit (ask your TA for permission before attempting, 5 points)

Look-up a plot of the number of sunspots versus time that spans the last four hundred years. For about 50 years, centered around 1670, the Sun was unusually “quiet”, in that sunspots were rarely seen. This event was called the “Maunder minimum” (after the discoverer). At the same time as this lack of sunspots, the climate in the northern hemisphere was much colder than normal. The direct link between sunspots and the Earth’s climate has not been fully established, but there must be some connection between these two events. Near 1800 another brief period of few sunspots, the “Dalton minimum” was observed. Looking at recent sunspot numbers, some solar physicists have suggested the Sun may be entering another period like the Dalton minimum. Search for the information these scientists have used to make this prediction. Describe the climate in the northern hemisphere during the last Dalton minimum. Are there any good ideas on the link between sunspot number and climate that you can find?

Name: _____

Date: _____

8 Mapping the Galaxy

8.1 Introduction

When we look up at the night sky we see many different kinds of objects. Objects you can see with the naked eye are mostly stars and planets, although in the Southern Hemisphere, two nearby galaxies are visible. With a small telescope, one can see “globular clusters”, “open clusters”, “gaseous nebulae” and “galaxies”. One very prominent feature which can be seen without the use of a telescope (in a dark location), is a swath of light that sweeps across the sky in a broad arc, the Milky Way. We know the Milky Way is a vast collection of stars that orbit about the center of our Galaxy in a flattened distribution resembling a plate or disk. This disk is often called the Milky Way or the Milky Way disk. It is but one of the components that make up our Galaxy.

In this lab, we will try to determine the shape of the Milky Way and our location in it based on observations of the distribution of several different types of objects in the sky.

- *Goals:* to determine the shape of our Galaxy and our place in it by observing patterns in the distributions of star clusters and nebulae
- *Materials:* Galaxy map, colored pencils or markers, scissors, tape, skewer

8.2 Getting used to the ideas

We are trying to determine the shape of our galaxy and our location in it. Since the Galaxy is so large, we cannot go outside of it and see what it looks like; instead, we have to infer what it looks like from our vantage point within the Galaxy.

The situation is even more complicated because, when we look at astronomical objects from the Earth, we cannot easily distinguish *how far away* the objects are. We only see in what direction they appear, but two objects which appear in the same direction are not necessarily at the same distance.

8.3 Map Projections

A hard aspect for some students to grasp is the idea of map projections. If you have completed the “Terrestrial Planets” lab, we discussed the idea of how a spherical object (such as the Earth) can be represented on a flat sheet of paper. In Figure 8.1 is a standard map of the Earth called a “Mercator Projection”. Near the equatorial regions, this type of projection is not too bad, but as you move to the poles, the projection is terrible! Antarctica appears to have more land than all of the other continents combined, but in reality is much smaller than North America. This is because you cannot perfectly plot a sphere on a rectangular grid.

Map makers have come up with a variety of ways to make better maps that more correctly represent the actual sizes of objects on a sphere. For example, the “Mollweide” projection seen in Figure 8.2 uses a complex formula to *do a better job* at rendering the sizes and shapes

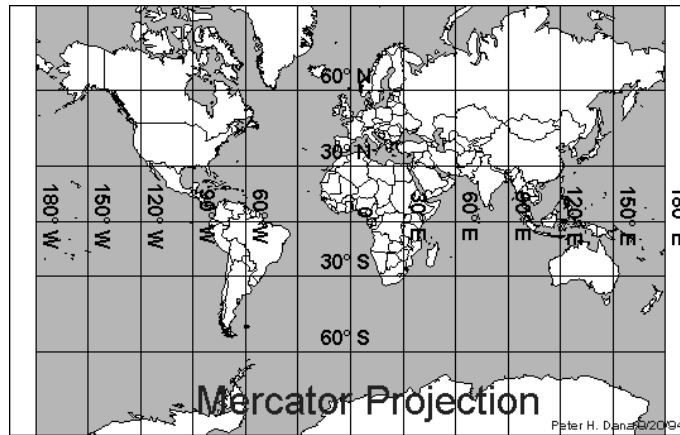

Figure 8.1: A “Mercator” projection of the Earth.

of the Earth’s continents, though it also fails really close to the poles.

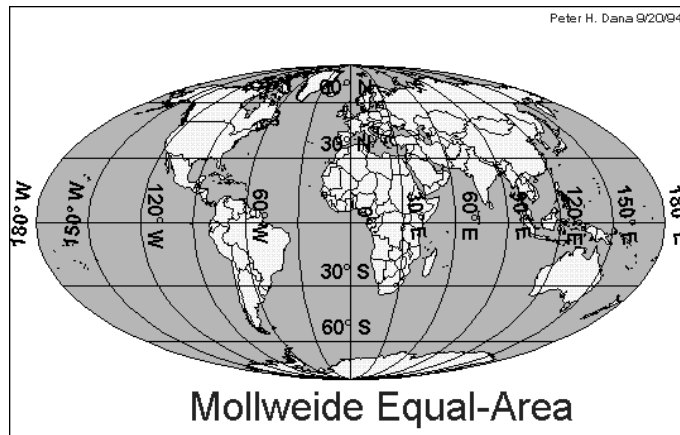

Figure 8.2: A “Mollweide” projection of the Earth.

A clever way to make a map of a globe is to mentally start with a spherical globe of paper, and then peel off segments of that sphere (like peeling an orange) so that we end up with a ragged, but more accurate representation of the Earth’s surface. An example is shown in Figure 8.3. Here it is slightly more difficult to make out the continents, but we could cut out this map with scissors and tape the pieces back together to construct a spherical globe!

On such a map, objects on the far left are actually very near to objects on the far right. This is the type of map we will use in this exercise. Sitting on the Earth’s surface, the sky appears to be a spherical entity that surrounds us—it is like a globe surrounding the globe of the Earth (ask your TA to show you the “celestial sphere” we have in the back room if they haven’t brought it out for you to look at).

To develop your intuition about this sort of map, let’s each make a map of the directions of all of your fellow students. Let’s imagine that we are each standing inside of a globe and

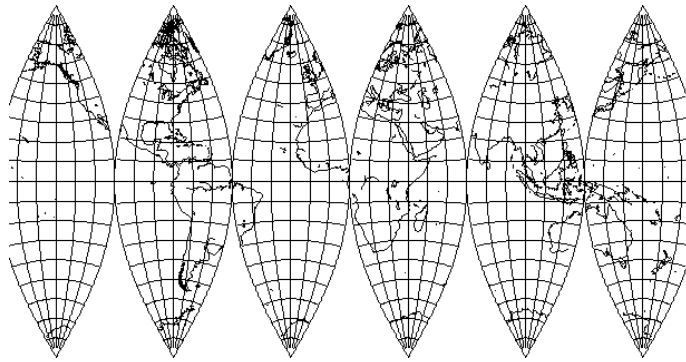

Figure 8.3: A map of the Earth made by “peeling” a sphere apart and plotting the result on a flat sheet of paper.

you can see all the other students in different directions. Let’s all agree that “north” should be up towards the ceiling, that the left-most panel in the map is looking towards the front of the classroom, and that panels to the right move in a clockwise fashion around the classroom (so the right most panel is almost all the way back to the front again). Remember that we are imagining that you don’t know anything about the distance to each student, only what direction they are seen in.

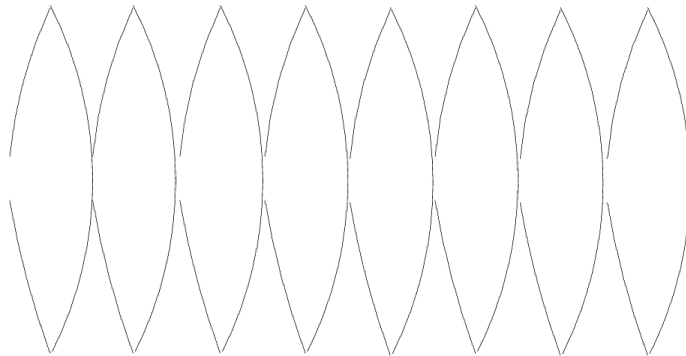

Figure 8.4: Map of students in this classroom.

Now let’s compare the maps. How do the maps differ for students in the middle of the classroom from those of students at the edge of the classroom?

Now let’s imagine we can reconfigure the students so they are distributed uniformly throughout the room. This means there are students above and below you as well as around you! However, there may be more students in some directions than in others, depending on where you are located in the classroom. Again, make a map of the directions of your fellow students.

Again, let’s compare the maps. How do the maps differ for students in the middle of the

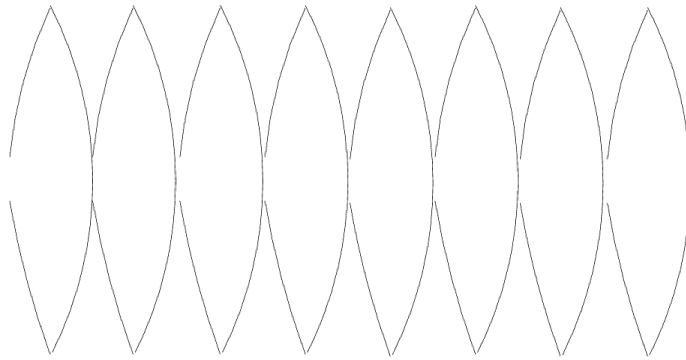

Figure 8.5: The map if students were distributed uniformly in every direction.

classroom from those of students at the edge of the classroom?

Let's summarize by drawing maps for four different idealized situations:

You are at the center of a uniform distribution of objects.

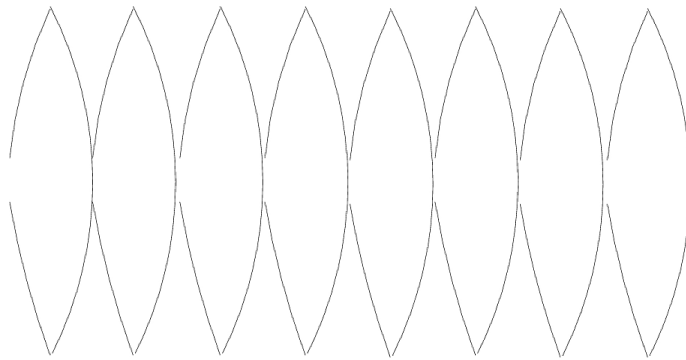

Figure 8.6: You are at the center of a uniform distribution of objects.

You are at the edge of a uniform distribution of objects.

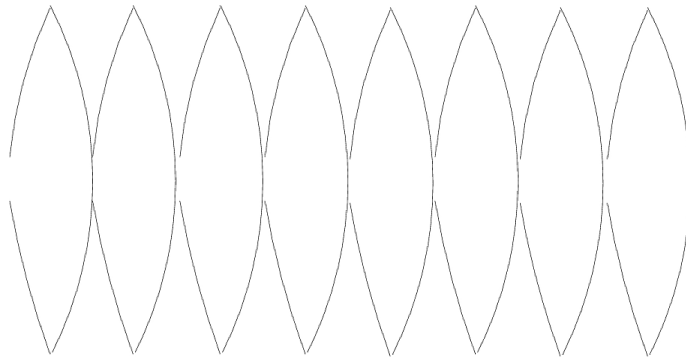

Figure 8.7: You are at the edge of a uniform distribution of objects.

You are at the center of a flattened distribution of objects.

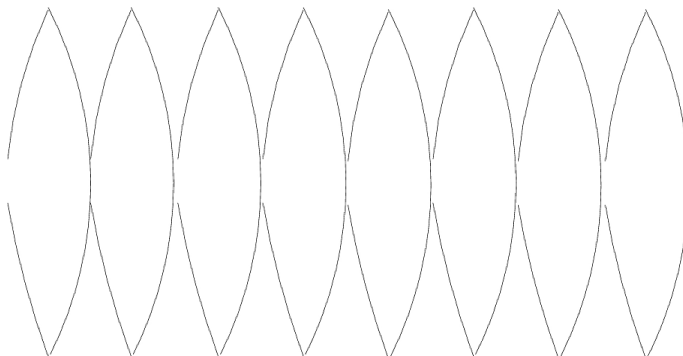

Figure 8.8: You are at the center of a flattened distribution of objects.

You are at the edge of a flattened distribution of objects.

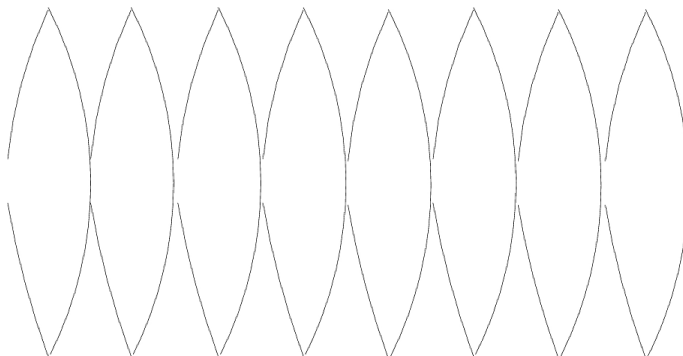

Figure 8.9: You are at the edge of a flattened distribution of objects.

One final thing to consider for the flattened distribution of objects: how does the appearance of objects on the map depend on the choice of where you put the North Pole?

8.4 The Contents of Our Milky Way Galaxy

Before we begin this lab, we should briefly introduce (or re-introduce) you to the various types of objects we will be plotting on our map. The band of light we call the Milky Way is in fact the sum of the light from billions of faint, and distant stars. Stars, and objects containing stars, are what we see with our eye, and those are the types of objects we will be plotting today. As you have/will find out in your lecture sessions, the Milky Way and other galaxies like it contain a number of objects that are not stars (such as molecular gas clouds), but these do not emit light that the human eye can detect (though we can infer their presence since they can absorb light!), and we will not be plotting those types of objects. Besides the band of light called the Milky Way, there are four types of objects we will plot today: Open clusters, Gaseous nebulae, Globular clusters and Galaxies. The first three of



Figure 8.10: The Pleiades, an “Open Cluster” of relatively young stars.

these all belong to our Milky Way galaxy, while galaxies are “Milky Ways” in their own right, and are located far beyond the boundaries of the Milky Way.

Depending on which labs your professor has chosen, you might have already encountered an “Open” cluster: the HR Diagram lab deals with the Pleiades, a well known Open cluster. A picture of the Pleiades is shown in Figure 8.10. The Pleiades consists of about 250 stars that are about 100 million years old. All of the stars in the Milky Way form in clusters. This is because they condense-out of cold molecular gas that is found in large clouds. Sometimes the gas cloud is small and produces a handful of stars, sometimes the gas cloud is large ($> 10^6 M_{\text{Sun}}$) and produces thousands of stars. Eventually, however, such a cluster will slowly fall apart, and the stars will wander off and circle the galaxy with unique orbits (when in a cluster, however, all of the stars orbit around the galaxy together as a single unit). This is why astronomers call them “Open”, they eventually fall apart. If they were “Closed”, they would not fall apart. Why do they fall apart? Because the gravity from very massive objects (such as molecular clouds) can pull Open clusters apart because they have relatively small ($< 5,000 M_{\text{Sun}}$) total masses.

In contrast, “Globular clusters” are “Closed”. Globular star clusters do not fall apart. An example is M15 shown in Figure 8.11. Globular star clusters contain 100,000 stars or more, and thus have large masses, and the gravity from all of these stars keeps them “bound”: Even as they pass by very massive objects, they cannot be pulled apart. Globular clusters are made up of some of the oldest stars found in our galaxy—in fact, most astronomers believe that Globular clusters were among the first objects that formed as the large gas cloud that was the “proto-Milky Way” collapsed.

“Gaseous nebulae” are closely related to Open clusters. When a cluster of stars first forms, much of the gas left over from the formation of stars is still present. The hotter stars in the cluster can “ionize” this gas (see the Spectroscopy lab), and cause it to glow. We see this gas as glowing knots and wisps of material surrounding the stars. The “Lagoon” Nebula, shown in Figure 8.12, is where several hundred young stars are being born. There is

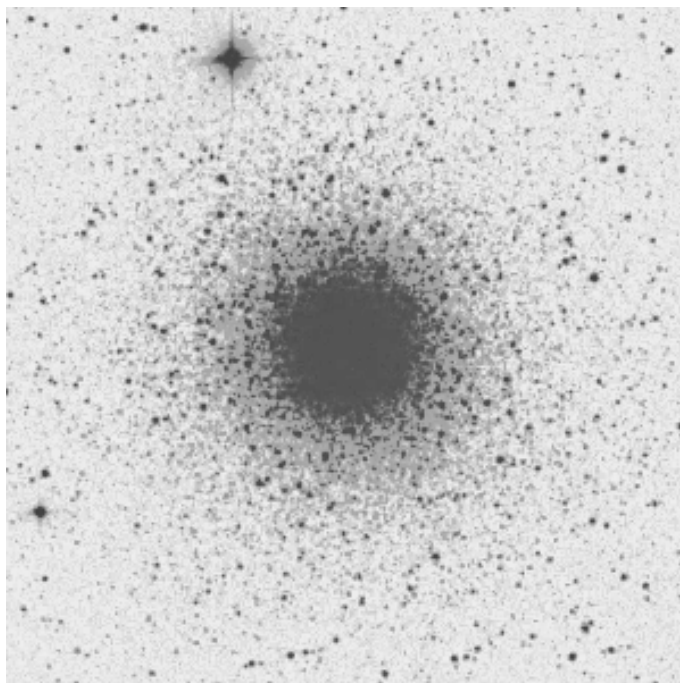

Figure 8.11: M15, a “Globular Cluster” which contains about 100,000 very old stars.

a lot of gas and dust that surrounds the very young open cluster at the center of the Lagoon, and such regions have complex structures.

As noted earlier, galaxies are large collections of objects mostly composed of stars, star clusters, gas, and dust. They are the hosts of Open clusters, Globular clusters and Gaseous nebulae (as well as molecular clouds, and some other objects we have not mentioned). To see some pretty pictures of galaxies, skip ahead to the “Galaxy Morphology” lab (the next lab in this manual), where images of several different types of galaxies are presented.

8.5 Exercises

Now we will create maps which show the distribution of different types of celestial objects in the sky. In Table 8.1 is a list of constellations within which bright objects can be observed using a small telescope. The list is separated into four subsections, one for each type of object: globular clusters, open cluster, gaseous nebulae and galaxies. For each object type we have listed names of constellations and the number of objects of each type which can be found within the constellations.

The figure at the end of this lab write-up has a blank map of the sky with the boundaries of all the constellations marked on it. This map is a bit like a map of the world that shows the borders between countries but nothing else. Remember however, when we are looking at the sky we are looking up at the inside of a sphere that completely surrounds us, not down onto the outside of the Earth. *The continuous band of stars already marked on the map is*

Table 8.1: Location of different objects in the sky

Constellation Name	Number of Globular Clusters	Number of Galaxies	Number of Open Clusters	Number of Gaseous Nebulae
Cepheus			3	6
Pegasus	4	2		
Aquarius	1			
Capricornus	4			
Grus		2		
Draco		5		
Cygnus			7	6
Vulpecula				4
Aquila			3	2
Sagittarius	20		2	3
Telescopium	8			
Hercules	4			
Ophiuchus	8			
Scorpius			6	
Lupus			2	1
Norma			4	
Ursa Majoris		16		
Canes Venatici		10		
Bootes	2			
Coma Bernaices	3	12		
Virgo	2	11		
Centaurus	2	5	1	4
Leo		8		
Hydra	1	2		
Camelopardalis		4		
Monoceros				8
Canis Major			6	3
Puppis			5	1
Perseus			4	5
Taurus			3	3
Orion			3	6
Eriadanus		8		
Dorado	3	4		
Cassiopeia			8	7
Andromeda		4		
Triangulus		7		
Pisces		3		
Cetus		7		
Fornax		2		
Sculptor	1	5		

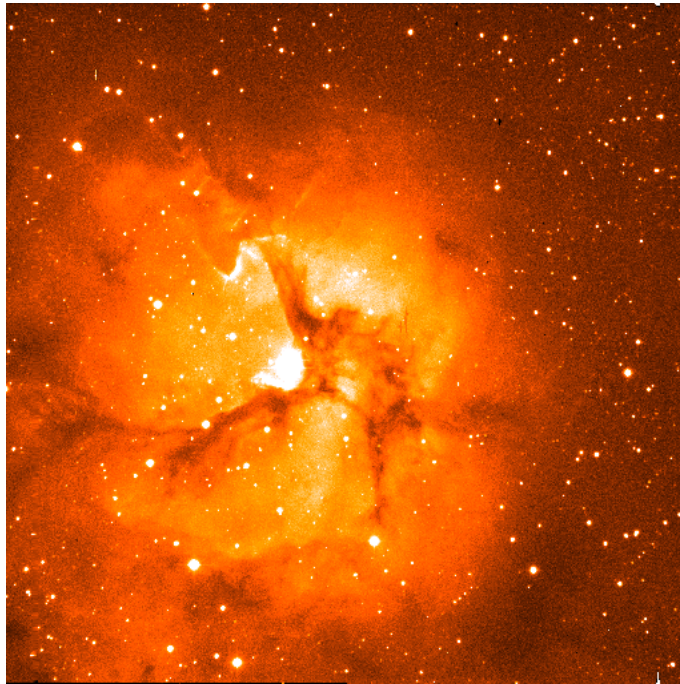

Figure 8.12: The Lagoon nebula, a gaseous nebula that contains several hundred young stars, some of which are so hot they ionize the hydrogen gas, causing it to glow.

the Milky Way.

For each type of object, your group will construct a separate celestial sphere. *In the end, you should have four celestial spheres, each with one type of object marked on it.*

Complete the following steps to construct each sphere:

1. Mark the location of each object in your set on the celestial sphere map. As an approximation, just place the marks near the center of the constellation the objects are in. The marks should be dark and large enough so that you can see the marks on the other side of the sheet.
2. Use a different color for each type of object. This will help you distinguish the different types of celestial spheres. (Remember that each sphere will have only one type of object marked on it.)
3. Cut out the map by cutting along the outside bold-face lines. Be sure it NOT to cut off the tabs at the top and bottom of each of the map subsections. These are essential for the proper construction of the globes.
4. A celestial sphere can be constructed using tape and skewers (be careful!). Your TA will give you more detailed instructions. Be sure that the skewers go through the small circles on the tabs at the top and bottom of each of the subsections of the map.

5. Be sure to construct your celestial sphere inside out because the Earth is really at the center of this “globe”. The objects we see are above and around us so when we construct these spheres, the marks should be on the inside surface of the sphere.

Describe the distribution of each type of object. Work as a group with each celestial globe and describe the distribution you observe for each type of object. Be as detailed as possible and make references to the plane of the Milky Way which has already been marked on each map and also the *center of the Milky Way Galaxy which is toward the constellation Sagittarius*. This information will be used to complete the questions so make sure you take good notes! **(20 points)**

Milky Way:

Open Clusters:

Gaseous Nebulae:

Globular Clusters:

Galaxies:

8.6 Questions

The following questions are intended to help you reconstruct the shape of our galaxy based on the exercises done in the lab. Be sure to answer all parts of the questions and use complete sentences as always.

1. Do any of the descriptions of the idealized distributions of objects discussed in subsection 8.2 (i.e. center of flattened distribution, edge of flattened distribution, center of uniform distribution, edge of uniform distribution) match the descriptions of the distributions of the celestial objects? If so, which ones? Explain your reasoning. **(10 points)**
2. Considering the answer to the previous question, where do you think we are located with respect to the system of globular clusters? open clusters? gaseous nebulae? Explain your reasoning. **(10 points)**
3. Draw a sketch of the Galaxy based on your answers to Questions 1 and 2. Draw your picture showing our location relative to the distributions of the four types of objects. Be sure to include all four types of objects and label them. **(15 points)**
4. What do you think the distribution of galaxies, as compared with the distributions of the other objects, tells you about where galaxies are located? **(10 points)**

8.7 Summary (35 points)

Please summarize the concepts you learned from this lab. You might wish to discuss:

- Describe each of the 4 types of objects discussed in the lab.
- When you look up into the sky and see a band of stars, what does that tell you about the structure of the Galaxy you live in?
- Describe the difference (in terms of the 4 objects discussed in lab) in what you would see if you were *a)* standing in the center of our Galaxy, and *b)* standing at the edge of our Galaxy.
- What conclusions can you draw about the distribution of objects in our galaxy and beyond?

Use complete sentences, and proofread your summary before handing in the lab.

8.8 Possible Quiz Questions

1. What is an open cluster?
2. What is an HII region?
3. What is a map projection?
4. Why are map projections used?

8.9 Extra Credit (ask your TA for permission before attempting, 5 points)

In this lab we have plotted objects that are in the Milky Way galaxy. What would the plot look like if we plotted external galaxies? Make sure to research this topic so that you have confidence in what you are plotting, and make a rough sketch of the distribution of external galaxies (or photocopy one of the “orange peel” diagrams and plot your galaxies on that)

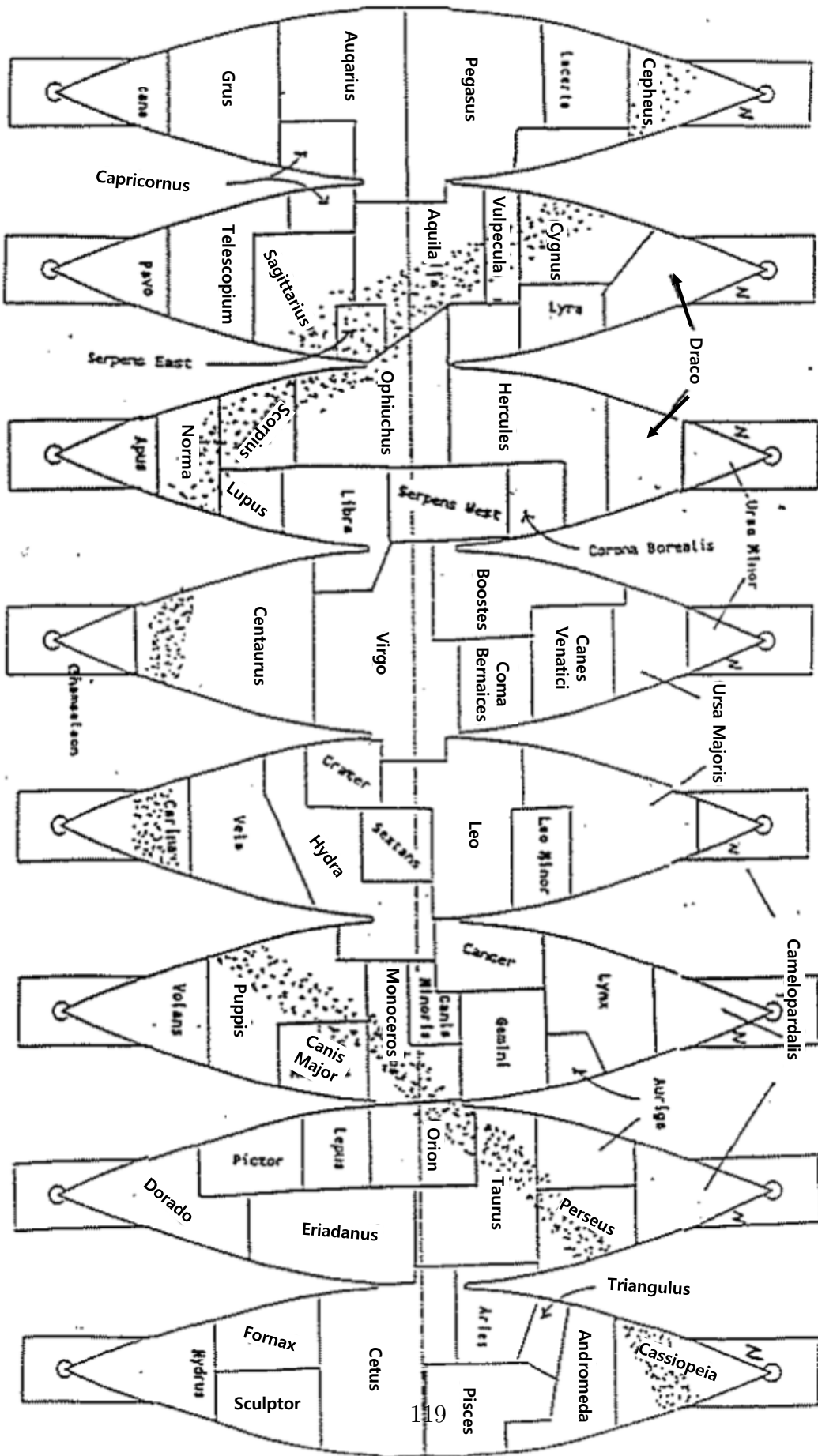

Name: _____

Date: _____

9 Galaxy Morphology

9.1 Introduction

Galaxies are enormous, “gravitationally bound” collections of millions, upon millions of stars. In addition to these stars, galaxies also contain varying amounts of gas and dust from which stars form, or from which they *have* formed. In the centers of some galaxies live enormous black holes that are sucking-in, and ripping apart stars and clouds of atomic and molecular gas. Galaxies come in a variety of shapes and sizes. Some galaxies have large numbers of young stars, and star forming regions, while others are more quiescent, mostly composed of very old, red stars. In today’s lab you will be looking at pictures of galaxies to become familiar with the appearances, or “morphology”, of the various types of galaxies, and learn how to classify galaxies into one of the three main categories of galaxy type. We will also use photographs/images of galaxies obtained using different colors of light to learn how the appearances of galaxies depend on the wavelength of light used to examine them.

- *Goals:* to learn about galaxies
- *Materials:* a pen to write with, a ruler, a calculator, and one of the notebooks of galaxy pictures

9.2 Our Home: The Milky Way Galaxy

During the summertime, if you happen to be far from the city lights, take a look at the night sky. During the summer, you will see a faint band of light that bisects the sky. In July, this band of light runs from the Northeast down to the Southwest horizon (see Fig. 9.1). This band of light is called the Milky Way, our home galaxy. Because we are located within the Milky Way galaxy, it is actually very hard to figure out its exact shape: we cannot see the forest for the trees! Thus, it is informative to look at other galaxies to attempt to compare them to ours to help us understand the Milky Way’s structure.

Galaxies are collections of stars, and clouds of gas and dust that are bound together by their mutual gravity. That is, the mass of all of the stars, gas and dust pull on each other through the force of gravity so that they “stick together”. Just like the planets in our Solar System orbit the Sun, the stars (and everything else) in a galaxy orbit around the central point of the galaxy. The central point in a galaxy is referred to as the “nucleus”. In some galaxies, there are enormous black holes that sit right at the center. These black holes can have a mass that is a billion times that of the Sun ($10^9 M_{\odot}$)! But not all galaxies have these ferocious beasts at their cores, some merely have large clusters of young stars, while others have a nucleus that is dominated by large numbers of old stars. The Sun orbits around the nucleus of our Milky Way galaxy (Fig. 9.2) in a similar fashion to the way the Earth orbits

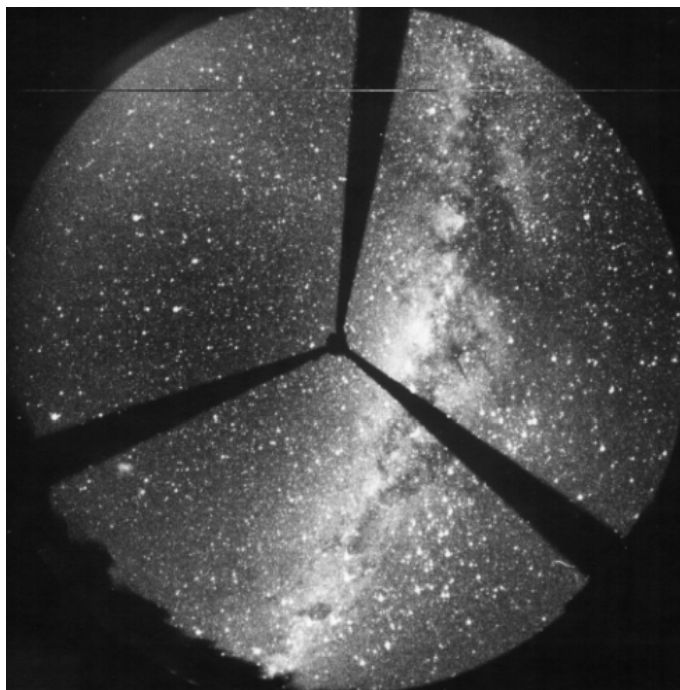

Figure 9.1: A fisheye lens view of the summertime sky showing the band of light called the Milky Way. This faint band of light is composed of the light from thousands and thousands of very faint stars. The Milky Way spans a complete circle across the celestial sphere because our solar system is located within the “disk” of the galaxy.

around the Sun. While it only takes one year for the Earth to go around the Sun, it takes the Sun more than 200 million years to make one trip around our galaxy!

Note that the central region (“bulge” and nucleus) of the Milky Way has a higher density of stars than in the outer regions. In the neighborhood of the Sun, out in the “disk”, the mass density is only $0.002 M_{\odot}/\text{ly}^3$ (remember that density is simply the mass divided by the volume: M/V , here the Mass is solar masses: M_{\odot} , and Volume is in cubic light years: ly^3). In the central regions of our Milky Way galaxy (within 300 ly of the center), however, the mass density is 100 times higher: $0.200 M_{\odot}/\text{ly}^3$. What does this mean? The nearest star to the Sun is Alpha Centauri at 4.26 ly. If we were near the nucleus of our Milky Way galaxy, there would be 200 stars within 4.26 ly of the Sun. Our sky would be ablaze with dozens of stars as bright as Venus, with some as bright as the full moon! It would be a spectacular sight.

Our Milky Way galaxy is a spiral galaxy that contains more than 100 billion stars. While the Milky Way is a fairly large galaxy, there are much larger galaxies out there, some with 100 times the mass of the Milky Way. But there are an even larger number of very small “dwarf” galaxies. Just like the case for stars, nature prefers to produce lots of little galaxies, and many fewer large galaxies. The smallest galaxies can contain only a few million stars, and they are thousands of times smaller than the Milky Way.

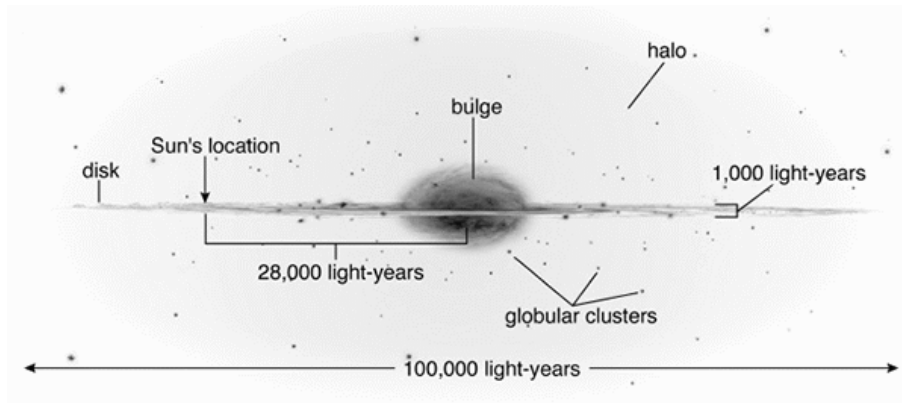

Figure 9.2: A diagram of the size and scale of our “Milky Way” galaxy. The main regions of our galaxy, the “bulge”, “disk”, and “halo” are labeled. Our Milky Way is a spiral galaxy, with the Sun located in a spiral arm 28,000 ly from the nucleus. Note that the disk of the Milky Way galaxy spans 100,000 ly, but is only about 1,000 ly thick. While the disk and spiral arms of the Milky Way are filled with young stars, and star forming regions, the bulge of the Milky Way is composed of old, red stars.

9.3 Galaxy Types: Spirals Ellipticals, and Irregulars

Shortly after the telescope was invented, astronomers started scanning the sky to see what was out there. Among the stars, these first astronomers would occasionally come across a faint, fuzzy patch of light. Many of these “nebulae” (Latin for cloud-like) appeared similar to comets, but did not move. Others of these nebulae were resolved into clusters of stars as bigger telescopes were constructed, and used to examine them. Some of these fuzzy nebulae, however, did not break-up into stars no matter how big a telescope was used to look at them. While many of these nebulae are clouds of glowing hydrogen gas within the Milky Way galaxy (HII regions), others (some of which resembled pinwheels) were true galaxies—similar to the Milky Way in size and structure, but millions of light years from us. It was not until the 1920’s that the actual nature of galaxies was confirmed—they were true “Island Universes”, collections of millions and billions of stars. As you will find out in your lecture sessions, the space between galaxies is truly empty, and thus most of the matter in the Universe resides inside of galaxies: *They are islands of matter in an ocean of vacuum.*

Like biologists or other scientists, astronomers attempt to associate similar types of objects into groups or classes. One example is the spectral classification sequence (*OBAFGKM*) for stars. The same is true for galaxies—we classify galaxies by their observed properties. It was quickly noticed that there were two main types of galaxies, those with pinwheel shapes, “spiral galaxies”, and smooth, mostly round or oval galaxies, “elliptical” galaxies. While most galaxies could be classified as spirals or ellipticals, some galaxies shared properties of both types, or were irregular in shape. Thus, the classification of “irregular”. This final category is a catch-all for any galaxy that cannot be easily classified as a spiral or elliptical. Most irregular galaxies are small, messy, unorganized clumps of gas and stars (though some irregular galaxies result from the violent collisions of spiral and/or elliptical galaxies).

9.3.1 Spiral Galaxies

The feature that gives spiral galaxies their shape, and leads to their classification are their spiral arms. An example of a beautiful spiral is M81 shown in Fig. 9.3. A spiral galaxy like M81 resembles a whirlpool, or pinwheel: arms of stars, gas and dust that radiate in curving arcs from the central “bulge”.



Figure 9.3: The Sb spiral galaxy M81. Notice the nice, uniform spiral arms that are wound tightly around the large, central bulge. Inside the spiral arms, there are large regions of glowing gas called HII regions—where stars are being born. These stand out as knots or clumps in the spiral arms. The dark spots, lanes, and arcs are due to dust clouds that are associated with these star forming regions.

Other spiral galaxies, like M51 shown in Fig. 9.4, have less tightly wound spiral arms, and much smaller bulges. Finally, there are spiral galaxies with very tightly wound spiral arms that are dominated by their bulge, like the Andromeda galaxy (M31) shown in Fig. 9.5. The arms are so tightly wound, that it is hard to tell where one ends and the other begins. These types of galaxies also have much less star formation.

Spiral galaxies are classified by how tightly their arms are wound, and how large their central bulges are. There are three main types of spirals: Sa, Sb, and Sc. Sa spirals have large bulges and tightly wound arms, while Sc’s have very loosely wound arms, and small bulges. Sb’s are intermediate between Sa’s and Sc’s (of course, like M31, there are galaxies that fall halfway between two classes, and they are given names like Sab, or Sbc). The spiral classification sequence is shown in Fig. 9.6.

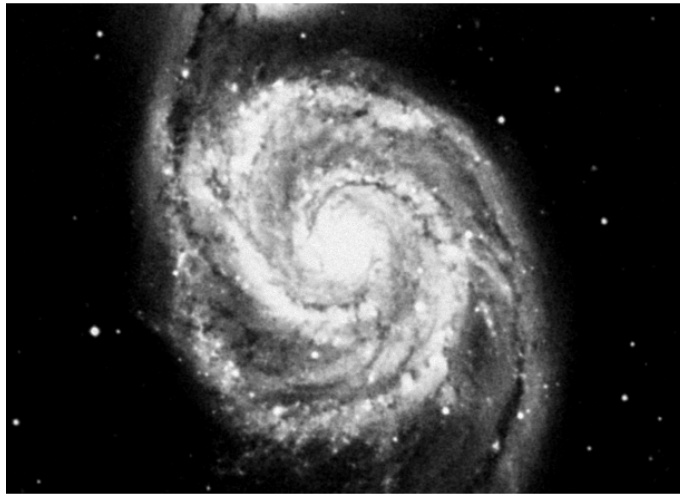

Figure 9.4: The Sc spiral galaxy M51. Notice the large, clumpy spiral arms that are loosely wound around the small, central bulge. Inside the spiral arms of M51 there are very many large HII regions—M51 has many young star forming regions. Notice that there is also a lot more dust in M51 than in M81.

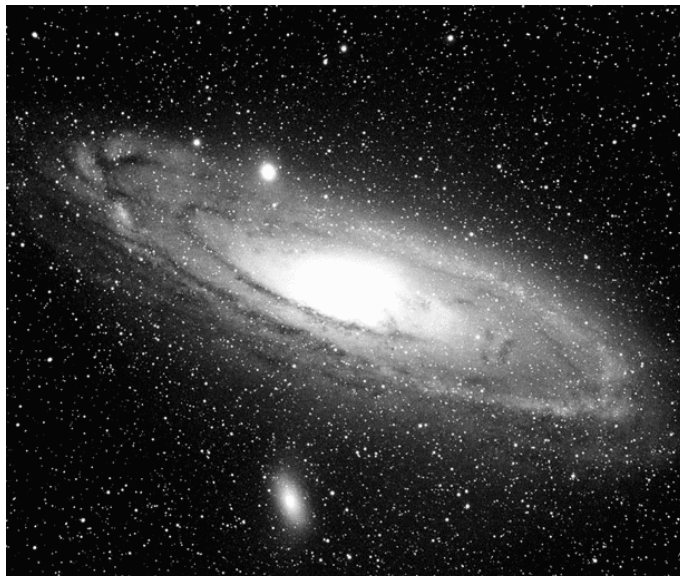

Figure 9.5: The Sab spiral galaxy M31. Notice the very large bulge, and very tightly wound spiral arms. Like the Milky Way, the Andromeda Galaxy has several small galaxies in orbit around it (just like planets orbit the Sun, some small galaxies can be found orbiting around large galaxies). Two of these galaxies can be seen as the round/elliptical blobs above and below the disk of the Andromeda galaxy shown here. Both are elliptical galaxies, discussed in the next subsection.

9.3.2 Elliptical Galaxies

Elliptical galaxies do not have as much structure as spiral galaxies, and are thus less visually interesting. They are smooth, round to elliptical collections of stars that are highly con-

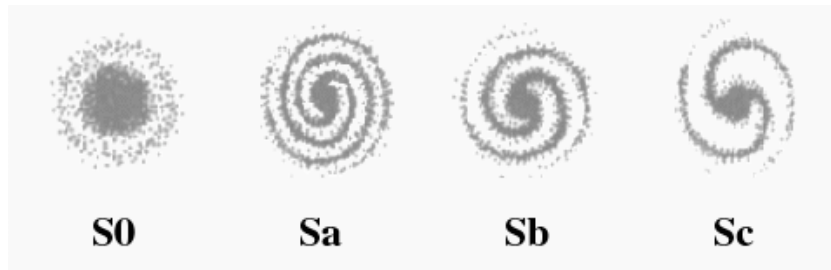

Figure 9.6: The classification sequence for spirals. S0 spirals are galaxies that show a small disk that is composed of only old, red stars, and have no gas, little dust and no star forming regions. They are mostly a large bulge with a weak disk, with difficult-to-detect spiral arms. They actually share many properties with elliptical galaxies. Sa galaxies have large bulges, and tightly wound spiral arms. Sb's have less tightly wound arms, while Sc's have very loosely wound arms, and have tiny bulges.

densed in their centers, that slowly fade out at their edges. Unlike spiral galaxies, where all of the stars in the disk rotate in the same direction, the stars in elliptical galaxies do not have organized rotation: the individual stars orbit the nucleus of an elliptical galaxy like an individual bee does in a swarm. While they have random directions, all of the billions of stars have well-defined orbits around the center of the galaxy, and take many millions of years to complete an orbit. An example of an elliptical galaxy is shown in Fig. 9.7.

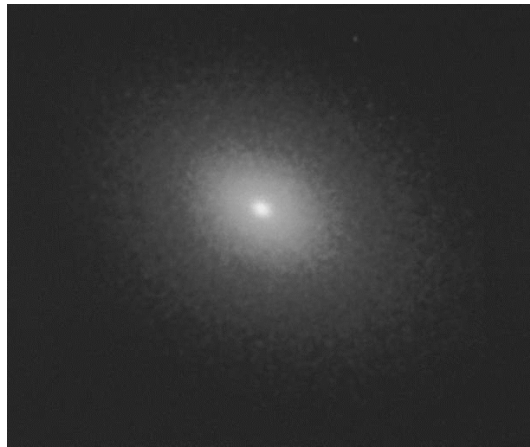

Figure 9.7: A typical elliptical galaxy, NGC205, one of the small elliptical galaxies in orbit around the Andromeda galaxy shown in Fig. ???. Most elliptical galaxies have a small, bright core, where millions of stars cluster around the nucleus. Just like the Milky Way, the density of stars increases dramatically as you get near the nucleus of an elliptical galaxy. Many elliptical galaxies have black holes at their centers. NGC205 is classified as an E5.

Elliptical galaxies can appear to be perfectly round, or highly elongated. There are eight categories, ranging from round ones (E0) to more football-shaped ones (E7). This classification scheme is diagrammed in Fig. 9.8.

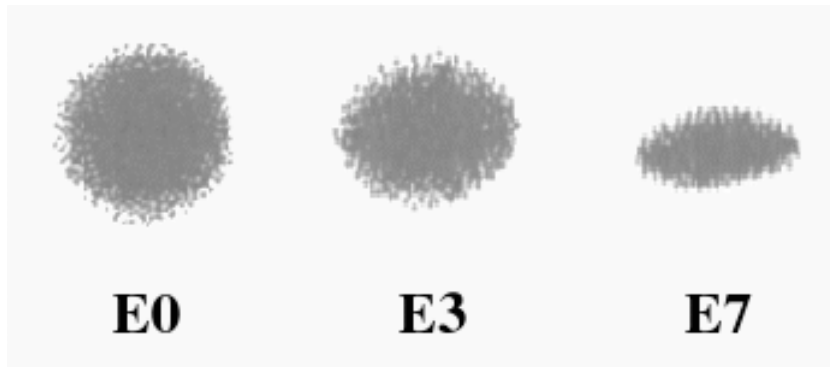

Figure 9.8: The classification scheme for elliptical galaxies. Elliptical galaxies range from round (E0), to football shaped (E7).

It is actually much easier to classify an elliptical galaxy, as the type of elliptical galaxy can be determined by measuring the major and minor axes of the ellipse. The definitions of the major and minor axes of an ellipse are shown in Fig. 9.9. To determine which type of an elliptical galaxy you are looking at, you simply measure the major axis (“a”) and the minor axis (“b”), and calculate: $10 \times (a - b) / a$. You will do this for several elliptical galaxies, below.

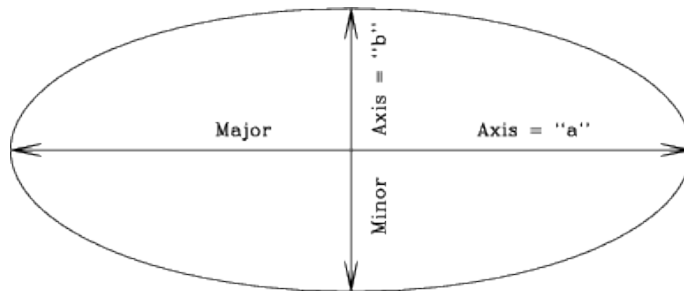

Figure 9.9: The definition of the major (“a”) and minor (“b”) axes of an ellipse.

9.3.3 Irregular Galaxies

As noted above, the classification of a galaxy as an “irregular” usually stems from the fact that it cannot be conclusively categorized as either a spiral or elliptical. Most irregular galaxies, like the LMC shown in Fig. 9.10, are small, and filled with young stars, and star forming regions. Others, however, result when two galaxies collide, as shown in Fig. 9.11.

9.3.4 Galaxy Classification Issues

We have just described how galaxies are classified, and the three main types of galaxies. Superficially, the technique seems straightforward: you look at a picture of a galaxy, note its main characteristics, and render a classification. But there are a few complications that make



Figure 9.10: The Large Magellanic Cloud (LMC). The LMC is a small, irregular galaxy that orbits around the Milky Way galaxy. The LMC (and its smaller cousin, the SMC) were discovered during Magellan’s voyage, and appear as faint patches of light that look like detached pieces of the Milky Way to the naked eye. The LMC and SMC can only be clearly seen from the southern hemisphere.

the process more difficult. In the case of elliptical galaxies, we can never be sure whether a galaxy is truly a round E0 galaxy, or an E7 galaxy seen from an angle. For example, think of a football. If we look at the football from one angle it is long, and pointed at both ends. But if we rotate it by 90° , it appears to be round. This is a “projection effect”, and one that we can never remove since we cannot go out and look at elliptical galaxies from some other angle.

As we will find out, spiral galaxies suffer from a different classification issue. When the Sa/Sb/Sc classification scheme was first devised, only photographs sensitive to blue light were used. If you actually look at spiral galaxies at other wavelengths, for example in the red or infrared, the appearance of the galaxy is quite different. Thus it is important to be consistent with what kind of photograph is used to make a galaxy classification. We will soon learn that the use of galaxy images at other wavelengths besides that which our eyes are sensitive to, results in much additional information.

9.4 Lab Exercises

For this lab, each group will be getting a notebook containing pictures of galaxies. *These notebooks are divided into five different subsections.* Below, there are *five subsections* with exercises that correspond to each of the five subsections in the notebook. Make sure to answer all of the questions fully, and to the best of your ability.

Section #1: Classification of Spiral Galaxies

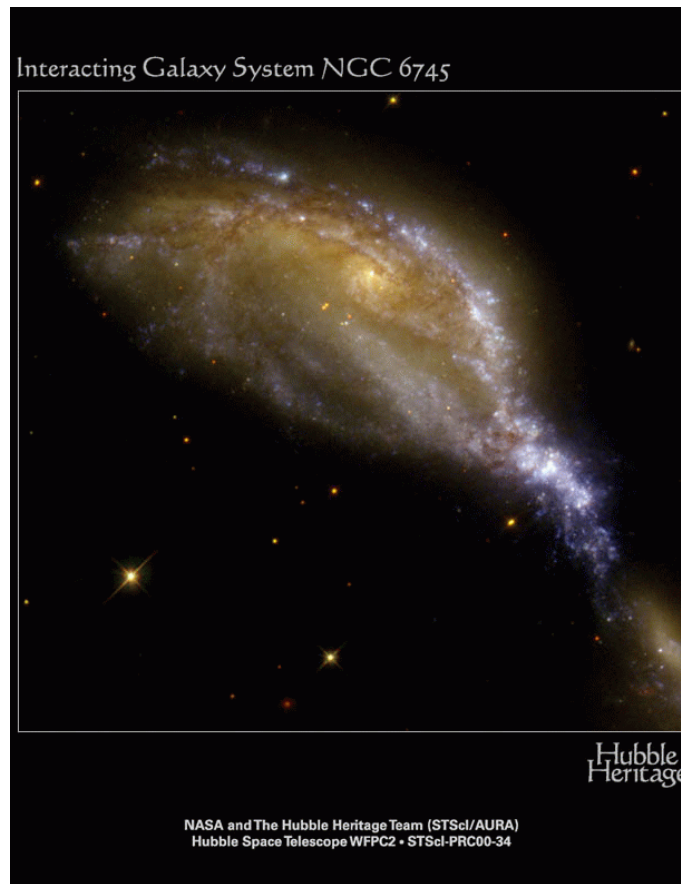

Figure 9.11: An irregular galaxy that is the result of the collision between two galaxies. The larger galaxy appears to have once been a normal spiral galaxy. But another galaxy (visible in the bottom right corner) ran into the bigger galaxy, and destroyed the symmetry typically found in a spiral galaxy. Galaxy collisions are quite frequent, and can generate a large amount of star formation as the gas and dust clouds are compressed as they run into each other. Some day, the Milky Way and Andromeda galaxies are going to collide—it will be a major disruption to our galaxy, but the star density is so low, that very few stars will actually run into each other!

In this subsection we look at black and white photographs of spiral galaxies. First you will see three standard spiral galaxies that define the Sa, Sb, and Sc subtypes, followed by more classification exercises.

Exercise #1: In pictures 1 through 3 are standard spiral galaxies of types Sa, Sb, Sc. Using the discussion above, and Figures 9.3 to 9.6, classify each of the spiral galaxies in these three pictures and describe what properties led you to decide which subclass each spiral galaxy fell into. **(3 points)**

Exercise #2: The pictures of the galaxies that you have seen so far in this lab are “positive” images, just like you would see if you looked at those galaxies through a large telescope—white means more light, black means less light. But working with the negative images is much more common, as it is much easier to see fine detail when presented as dark against a light background versus bright against a dark background. For example, Picture #4 is the negative image for Picture #1. Detail that is overlooked in a positive image can be seen in a negative image. For most of the rest of this lab, we will look at negative images like those shown in Picture #4.

Classify the spiral galaxies in Pictures #5, 6, 7 and 8. In each case, describe what led you to these classifications. **(4 points)**

Exercise #3: So far, we have looked at spiral galaxies that have favorable orientations for classification. That is, we have seen these galaxies from a direction that is almost perpendicular to the disk of the galaxy. But since the orientation of galaxies to our line of sight is random, many times we see galaxies from the side view. In this exercise, you will look at some spiral galaxies from a less favorable viewing angle.

In pictures #9, 10, and 11 are three more spiral galaxies. Try to classify them. Use the same techniques as before, but try to visualize how each subtype of spiral galaxy would change if viewed from the side. (Remember that in a negative image, bright white means no light, and dark means lots of light—so dusty regions show up as white!) **(3 points)**

Section #2: Elliptical Galaxies As described earlier, elliptical galaxies do not show very much detail—they are all brighter in the center, and fade away at the edges. The only difference is in *how* elliptical they are, ranging from round (E0) to football-shaped (E7). In this subsection will learn how to classify elliptical galaxies.

Exercise #4: In pictures #12, 13, 14, and 15 are some elliptical galaxies. Using Figure 9.8 as a guide, classify each of these four galaxies as either E0, E1, E2, E3, E4, E5, E6, or E7. Describe how you made each classification. **(4 points)**

Exercise #5: In our discussion about elliptical galaxy classification, we mentioned that there was a *quantitative* method to classify elliptical galaxies: you use the equation $10 \times (a - b)/a$ to derive the subclass number. In this equation “a” is the major axis (long diameter) and “b” is the minor axis (the short diameter). Go back to Figure 9.9 to see the definition of these two axes. For example, if you measured a value of $a = 40$ mm, and $b = 20$ mm, then the subclass is $10 \times (40 - 20)/40 = 10 \times (20/40) = 10 \times (0.5) = 5$. So that this particular elliptical galaxy is an E5.

If the measurements for an elliptical galaxy are $a = 30$ mm and $b = 20$ mm, what subclass is that galaxy? (Round to the nearest integer.) **(2 points)**

Measure the major and minor axes for each of the galaxies in pictures #12, 13, 14, and 15, and calculate their subtypes. Note: it can sometimes be hard to determine where the “edge”

of the galaxy is—try to be consistent and measure to the same level of brightness. **(4 points)**

It is pretty hard to measure the major and minor axes of elliptical galaxies on black and white photographs! Usually, astronomers use digital images, and then use some sort of image processing to make the task easier. Picture #16 is a digitized version of picture #15, processed so that similar light levels have the same color. As you can see, this process makes it much easier to define the major and minor axes of an elliptical galaxy.

Exercise #6: Measure the major and minor axes of the two elliptical galaxies shown in Pictures #16 and #17, and classify them using the same equation/technique as before. **(2 points)**

Section #3: Irregular Galaxies While most large galaxies in our Universe are either spirals or ellipticals, there are a large number of very strange looking galaxies. If we cannot easily classify a galaxy as a spiral or elliptical, we call it an Irregular galaxy. Some irregular galaxies appear to show some characteristics of spirals and/or ellipticals, others are completely amorphous blobs. Many of the most unusual looking galaxies are the result of the interactions between two galaxies (such as a collision). Sometimes the two galaxies

merge together, other times they simply pass through each other (see Fig. 9.11). Pictures 18 through 22 are of irregular galaxies.

Exercise #7: The peculiar shapes and features of the irregular galaxies shown in Pictures #18, 19 and 20 are believed to be caused by galaxy collisions or galaxy-galaxy interactions (that is, a close approach, but not a direct collision). Why do you think astronomers reached such a conclusion for these three galaxies? **(4 points)**

Exercise #8: In Pictures #21 and 22 are images of two “dwarf” irregular galaxies. Note the general lack of any structure in these two galaxies. Unlike the collision-caused irregular galaxies, these objects truly have no organized structures. It is likely that there are hundreds of dwarf galaxies like these in our Universe for every single large spiral galaxy like the Milky Way. So, while these dwarf irregular galaxies only have a few million stars (compared to the Milky Way’s 100+ billion), they are a significant component of all of the normal (“baryonic”) mass in our Universe. One common feature of dwarf irregular galaxies is their abundance of young, hot stars. In fact, more young stars are produced each year in some of these small galaxies than in our Milky Way, even though the Milky Way is 10,000 times more massive! Why this occurs is still not fully understood.

In the two dwarf irregular galaxies shown in Pictures #21 and 22, the large numbers of blue stars, and the high number of *bright* red supergiants (especially in NGC 1705) indicate a high star formation rate—that is lots of new, young stars. Why are large numbers of hot, luminous blue stars, and red supergiants linked to young stars? [Hint: If you have learned about the HR diagram, try to remember how long hot, blue O and B stars live. As their internal supply of hydrogen runs out, they turn into red supergiants.] **(4 points)**

Section #4: Full Color Images of Galaxies

As we have just shown, color images of galaxies let us look at the kinds of stars that are present in them. A blue color indicates hot, young O and B stars, while a predominantly red, or yellow color indicates old, cool stars (mostly red giants). In this subsection we explore the kinds of stars that comprise spiral and elliptical galaxies.

Exercise #9: Comparison of Spirals and Ellipticals

In Pictures #23 through 27 we show some color pictures of elliptical and spiral galaxies. Describe the average color of an elliptical galaxy (i.e., #23 & #24) compared to the colors of spiral galaxies (#25 to #27). **(3 points)**

Now, let's look more closely at spirals and ellipticals. When examining the color pictures of the spiral galaxies you should have noticed that the spiral arms are generally bluer in color than their bulges. Hot young stars are present in spiral arms! That is where all of the young stars are. But in the bulges of spirals, the color is much redder—the bulge is made up of mostly old, red stars. In fact, the bulges of spiral galaxies look similar to elliptical galaxies. Compare the large bulge of the Sombrero galaxy (Picture #27) to the giant E0 galaxy M87 (Picture #23). **(3 points)**

If the bulges of spiral galaxies are made-up of old, red giant stars, what does this say about elliptical galaxies? **(3 points)**

It is likely that you have learned about the emission of light by hydrogen atoms in your lecture sessions (or during the spectroscopy lab). Hydrogen is the dominant element in the Universe, and can be found everywhere. The brightest emission line in the visual spectrum of hydrogen is a red line at 656 nm. This gives glowing hydrogen gas a pinkish color. When we take pictures of glowing clouds of hydrogen gas they are dominated by this pink light. During the course of this semester, you will also hear about ‘HII’ regions (such as the “Orion Nebula”, see the monthly skycharts for February found in the back of this lab manual). HII regions form when hot O and B stars are born. These stars are so hot that they ionize the nearby hydrogen gas, causing it to glow. When we look at other spiral galaxies, we see many HII regions in them, just like those found in our Milky Way.

Of the spiral galaxies shown in Pictures 25 to 27, which has the most HII regions? Which appears to have the least? What does this imply about M51? **(3 points)**

Section #5: Multi-wavelength Views of Galaxies

We now want to explore what galaxies look like at ultraviolet and infrared wavelengths. “Multi-wavelength” data provides insights that cannot be directly gleaned from visual images.

We have just finished looking at some color images of galaxies. Those color pictures were

actually made by taking several images, each through a different color filter, and then combining them to form a true-color image. Generally astronomers take pictures through a red, green, and blue filter to generate an “RGB” color picture. Many computer programs, such as Adobe Photoshop, allow you to perform this type of processing. Sometimes, however, it is best not to combine several single-color images into a color picture—subtle detail is often lost. Also, astronomers can take pictures of galaxies in the ultraviolet and infrared (or even X-ray and radio!), light which your eye cannot detect. There is no meaningful way to represent the true colors of a galaxy in an ultraviolet or infrared picture. Why would astronomers want to look at galaxies in the ultraviolet or infrared? Because different types of stars have different colors, decomposing the light of galaxies into its component colors allows us to determine how such stars are distributed (as well as gas and dust). In Pictures #28 and 29 we present blue and red images of the spiral galaxy M81. As you have just learned, the bulges of spiral galaxies are red, and the spiral arms (and disks) of spiral galaxies are blue. Note how the red image highlights the bulge region, while the blue image highlights the disk. Hot stars emit blue light, so if we want to see how many blue stars there are in a galaxy, it is best to use blue, or even ultraviolet light.

In this part of the lab, we will look at some multi-wavelength data. Let’s remind ourselves first about the optical part of the electromagnetic spectrum. It runs from ultraviolet (“U”, 330 nm), to blue (“B”, 450 nm), through green/visual (“V”, 550 nm), to yellow, red (“R” 600 nm) and infrared (“I”, 760 nm and longer). The high energy photons have shorter wavelengths and are ultraviolet/blue, while the low energy photons have longer wavelengths and are red/infrared. If we go to shorter wavelengths than those that can penetrate our atmosphere, we enter the true ultraviolet (wavelengths of 90 to 300 nm). These are designated by UV or FUV (FUV means “far” ultraviolet, below 110 nm). We will now see what galaxies look like at these wavelengths—but note that we will switch back to black and white photos.

Exercise #10: Comparison of Optical and Ultraviolet Images of Galaxies

In Picture #30 are three separate images of two spiral galaxies. In the left hand column are FUV, U and I images of the Sc galaxy NGC 1365, and in the right hand column are FUV, U and R images of the Sa galaxy NGC 2841. Remember that images in the FUV, UV, U and B filters look at hot stars, while images in V, R, and I look at cooler stars. The ultraviolet really only sees hot stars! Compare the number of hot stars in NGC 1365 with NGC 2841. Describe the spiral arms of NGC 2841. What do you think is happening in the nucleus of NGC 2841? (4 points)

In Picture #31 are FUV, U and R images of two more galaxies: the Sc galaxy NGC 2403, and the irregular galaxy IC 2574. Compare the number of red and blue stars in these two galaxies—are they similar? What is the main difference? **(3 points)**

In Picture #32 is a similar set of images for two elliptical galaxies, NGC 5253 and NGC 3115 (which can also be seen in Pictures #15 and 16) Compare these two galaxies. While NGC 3115 is a normal elliptical galaxy, NGC 5253 seems to have something interesting going on near its nucleus. Why do we believe that? Describe how we might arrive at this conclusion? **(3 points)**

Exercise #11: Comparison of Optical and Infrared Images of Galaxies

Ok, now let's switch to the infrared. Remember that cool stars emit most of their energy in the red, and infrared portions of the electromagnetic spectrum. So if we want to trace where the cool, red (and old) stars are, we use red or infrared images. Another benefit of infrared light is its power to penetrate through dust, allowing us to see through dusty molecular gas clouds.

In Pictures #33 through #35 are blue ("B", 450 nm) and infrared ("H", 1650 nm) images of spiral galaxies. In Picture #33 we have Sa galaxies, in #34 we have Sb galaxies, and in #35 we have Sc galaxies. Compare how easy/hard it is to see the spiral arms in the B images

versus the H images. Where are the blue stars? Where are the red stars? Note that while the hot O and B stars are super-luminous (1 million times the Sun's luminosity), they are very rare. For each O star in the Milky Way galaxy there are millions of G, K, and M stars! Thus, while an O star may have 60 times the Sun's mass, they are tiny component of the total mass of a spiral galaxy. Thus, what does the infrared light trace? **(5 points)**

Finally, let's take a look at the Milky Way galaxy. As we mentioned in the introduction, we are embedded in the disk of the Milky Way galaxy, and thus it is hard to figure out the exact shape and structure of our galaxy. In Picture #36 is an optical picture that spans the entire sky—we see that our Milky Way galaxy has a well-defined disk. But in the optical photograph, it is difficult to ascertain the bulge of the Milky Way, or the symmetry of our galaxy—there is just too much dust in the way! Picture #37 is an infrared view that is identical to the previous optical image. What a difference! We can now see through all of that dust, and clearly make out the bulge—note how small it is. We think that the Milky Way is an Sc galaxy (This lab was written several years ago, we now understand the Milkyway

galaxy to be a Barred Spiral Galaxy). Make an argument in support of this claim of why we would think the Milkyway was a Sc Galaxy, compare it to the photographs of other tilted spiral galaxies from Exercise #3. [Note: both of these images are special “projections” of the celestial sphere onto a two-dimensional piece of paper. This “Aitoff” projection makes sure the sizes and shapes of features are not badly distorted. For proper viewing, the right hand edge of these pictures should be wrapped around so that it touches the left hand edge, and you would have to be viewing the picture from inside to get a proper perspective. It is hard to take a three dimensional picture of the sky and represent it in two dimensions! A similar problem is encountered when using a rectangle to make a map of our globe (see the Terrestrial planet lab.) **(8 points)**

9.5 Summary (35 points)

Summarize the important concepts of this lab, including the following topics.

- Describe the process for classifying a spiral galaxy.
- Describe the process for classifying an elliptical galaxy.
- What are the main difficulties in classifying these two main types of galaxies (they may not be the same issues!).
- What kind of information does multi-wavelength data (images) on galaxies provide? How is it useful? What does it tell us?
- What types of stars are found in spiral galaxies? In ellipticals? What does this tell us about elliptical galaxies?
- What types of stars are found in dwarf irregular galaxies?

9.6 Possible Quiz Questions

1. What are the three main types of galaxies?
2. What are the major components of the Milky Way and other Spiral galaxies?
3. How big is the Milky Way, and how many stars does it contain?
4. What are O and B stars like? How long do they live? What are red supergiants?
5. What are HII regions?
6. Draw the electromagnetic spectrum and identify the visual, infrared and ultraviolet regions.

9.7 Extra Credit (ask your TA for permission before attempting, 5 points)

In the introduction we mentioned that many galaxies (including the Milky Way) have large black holes at their centers. These black holes rip apart stars and suck in the gas. As the gas falls in, it gets very hot, and emits a lot of X-rays, ultraviolet and blue light. Compared to the galaxy, this hot gas region is tiny, and shows up as a small bright spot at the nucleus of the galaxy in the ultraviolet. Go back to Pictures 30 to 32 and list which of the galaxies appear to have black holes at their centers. How did you reach your conclusion?

Name: _____

Date: _____

10 How Many Galaxies are there in the Universe?

10.1 Introduction

Measurements, calculations, physical principles and estimations (or educated guesses) lie at the heart of all scientific endeavors. Measurements allow the scientist to quantify natural events, conditions, and characteristics. However, measurements can be hard to make for practical reasons. We will investigate some of the issues with taking measurements in this lab.

In addition, an important part about the measurement of something is an understanding about the *uncertainty* in that measurement. No one, including scientists, ever make measurements with perfect accuracy, and estimating the degree to which a result is uncertain is a fundamental part of science. Using a result to prove or disprove some theory can only be done after a careful consideration of the uncertainty of the result.

- *Goals:* to discuss the concepts of estimation, measurement and measurement error, and to use these, along with some data from the Hubble Space Telescope, to estimate the number of observable galaxies in the Universe
- *Materials:* Hubble Deep Field image

10.2 Exercise Section

10.2.1 Direct Measurement, Measurement Error

We will start out by counting objects much closer to home than galaxies!

How many chairs do you think there are in your classroom? You have one minute!

How did you determine this?

How does your number compare with that of other groups? What does this say about the uncertainty in the results?

Now do an exact count of the number of chairs - you have three minutes. Note the advantage of working with a group! By comparing results from different groups, what is the uncertainty in the result?



Figure 10.1: A map of the NMSU campus from the NMSU WWW site

10.2.2 Estimation

Now we extend our measurement to a larger system where practical considerations limit us from doing a direct count.

How many chairs do you think there are in the entire University? You might wish to consider the campus map shown in Figure 10.1.

How did you determine your number?

How accurate do you think your number is?

How might you estimate the uncertainty in your number?

10.3 How many galaxies are there in the Universe?

Considering how you estimated the number of chairs in the classroom and on campus, consider and write down several alternative ways of estimating the number of galaxies in the Universe.

Let's consider the issue by looking at a picture of the sky taken with the Hubble Space Telescope. This telescope is the most capable of existing telescopes for viewing very faint objects. In an effort to observe the faintest galaxies, astronomers decided to spend 10 entire

days training this telescope on one small region of the sky to observe the faintest galaxies and learn about them. The image that was obtained is shown in Figure 10.2.

First, let's figure out how long it would take for the Space Telescope to take pictures like this over the entire sky.

To do this, we need to talk about how we measure distances and areas on the sky, concepts that we have used in some of the other labs this semester. When one measures, for example, the distance between two stars as seen from Earth, one measures what is known as an angular distance. A standard unit of this angular distance is the familiar unit of the degree; there are 360 degrees in a full circle. As an example, the distance between an object which is straight overhead and one which is on the horizon is 90 degrees. However, when one makes astronomical observations with big telescopes, one usually sees an area which is only a small fraction of a degree on a side. To make things easier to write, astronomers sometimes use units known as arcminutes and arcseconds. There are 60 arcminutes in a degree, and 60 arcseconds in an arcminute.

1. We can now use this information to calculate how many pictures the Space Telescope would have to make to cover the entire sky. The picture from the Space Telescope covers a region that is about 1 arcminute on a side. Our first conversion is from arcminutes to degrees (this has been partially done for you): **(3 points)**

$$1 \text{ arcminute} \times \frac{1 \text{ degree}}{60 \text{ arcminutes}} = \frac{\quad}{\quad} \text{ degrees} \quad (5)$$

2. The *area* of the entire picture is measured in square degrees, so we take the number of degrees found in question 1 and square it to get: **(3 points)**
3. Now there are 4.13×10^4 square degrees in the sky. From this you can figure out how many pictures you would need to take to cover the whole sky: **(5 points)**
4. Finally if it takes 10 days for each picture, we can figure out how long it would take to cover the whole sky with similar pictures: **(4 points)**
5. With a unit conversion of 365 days/year, we can determine the number of years it would take: **(4 points)**

Clearly, this is a very long time! This is an interesting point to note: astronomers can only take deep pictures of a small fraction of the sky. So it is not practical to count galaxies by taking pictures of the entire sky.

So how can we proceed to figure out how many total galaxies there are? We can make an *estimate* by guessing that the number of galaxies in any particular picture will be the

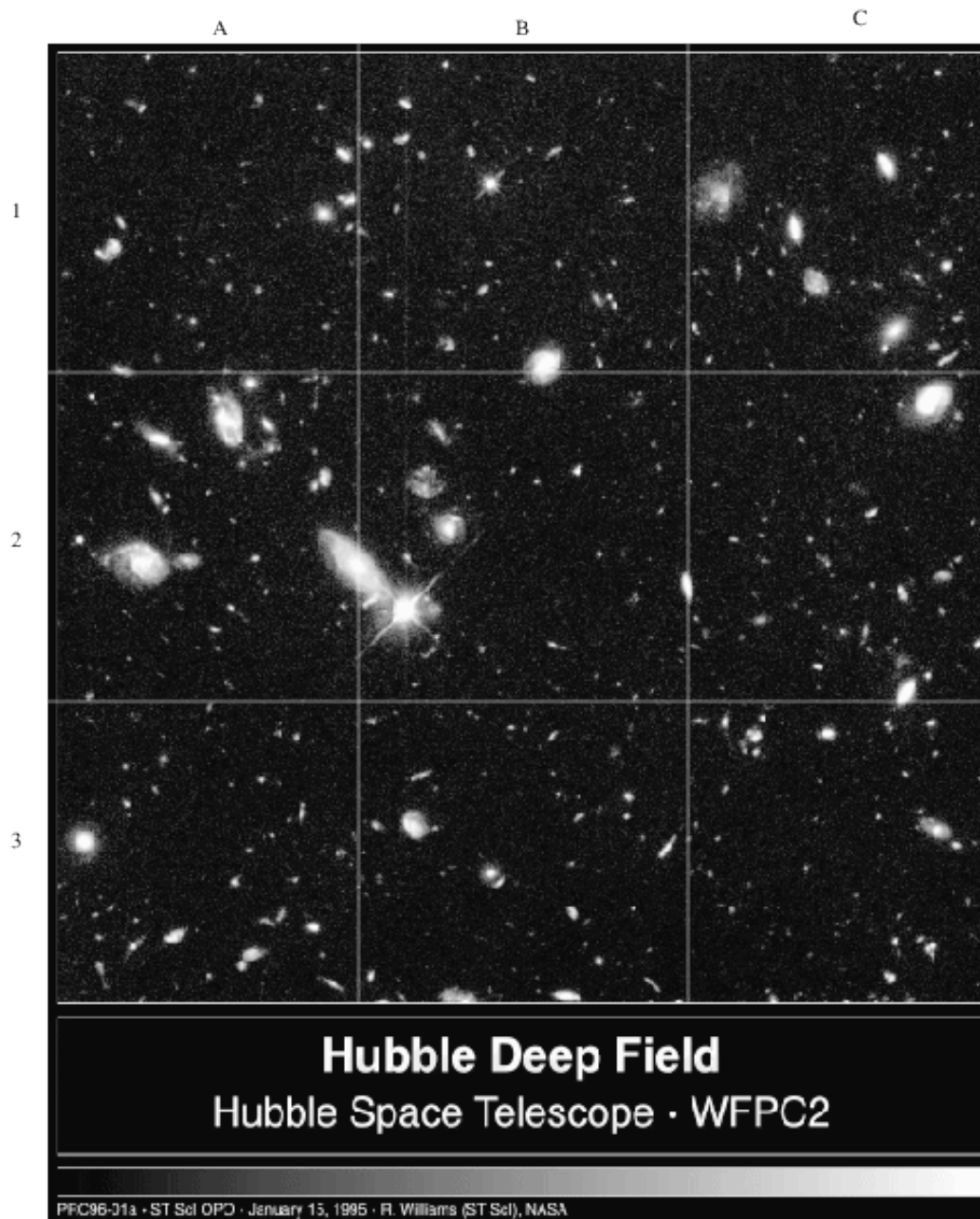

Figure 10.2: A reproduction of the Hubble Deep Field image.

same regardless of where we point. We can then estimate the total number of galaxies in the sky by counting the number of galaxies in this one picture, and multiplying it by the number of pictures that it would take to cover the whole sky.

6. Take a look at the image of the Hubble Deep Field given to you by your TA. Almost every one of the objects you see in this picture is a distant galaxy. Count up all the galaxies in each subsection then add them up to get an estimate of the number of galaxies in this one field. Again, you can proceed quicker by taking advantage of the multiple members of your group; however, you might wish to have everyone in the group count one region independently to get some idea of the measurement uncertainty. **(10 points)**

Region A1:

Region A2:

Region A3:

Region B1:

Region B2:

Region B3:

Region C1:

Region C2:

Region C3:

There are a total of galaxies in Hubble Deep Field.

7. Now estimate the total number of galaxies in the whole sky, using our calculation of the number of pictures it takes to cover the sky which we did above. **(7 points)**

This is a pretty amazingly large number. Consider that each galaxy has billions of stars, and think just for minute about how many total stars there are in the Universe! It makes you feel pretty small.... but, on the other hand, think how cool it is that humans have evolved to the point where they can even make such an estimation!

8. As we've discussed, an estimate of the *uncertainty* in a result is often as important as the result itself. Discuss several reasons why your result may not be especially accurate. You may wish to compare the number of galaxies in any given region which you counted with the number counted by other groups, or consider the variation in the number of galaxies from one region to another. Also, remember a fundamental assumption that we made for getting our estimate, namely, that the number of galaxies we would see in some other portion of the sky is the same as that which we see in this Hubble deep field. **(8 points)**

9. Finally, there's one more caveat to our calculated total number of galaxies. To make our estimate, we *assumed* that the 10 day exposure sees every single galaxy in this portion of the sky. With this in mind, how would the calculation you just conducted compare to the real number of galaxies in the Universe? Back up your answer with a short explanation. (8 points)

10.4 The Mass and Density of the Universe (Contained in Galaxies)

In the preceding we have estimated the number of galaxies in the Universe. In the final subsection of this lab, we now want to explore the implications of this calculation by making an estimate of the matter density of the Universe. In your lecture subsections, and some of the earlier labs you have probably encountered the concept of density: density = Mass/Volume. Astronomers usually use the unit of gm/cm³ for density. We can now make an estimate for the density of matter contained in all of the galaxies in our Universe. We will start with very large numbers, and end up with an extremely tiny number. It is quite likely that your calculator cannot handle such numbers. To make this calculation easier, we will use some round numbers so that you can do the calculation by hand using the techniques outlined in Lab 1. This is a challenging exercise, but one that gives you an answer that you might not expect!

10. In question 7 above, you estimated the total number of galaxies in the sky. If we assume that these galaxies are similar to (though probably somewhat smaller than) our Milky Way galaxy, we can calculate the total mass of all of the galaxies in the Universe. Over the course of this semester you will learn that the Milky Way has about 100 billion stars, and most of these stars are about the mass of the Sun, or somewhat smaller. The mass of the Sun is 2×10^{33} gm. Let's assume that the average galaxy in the Universe has 1/2 the number of stars that the Milky Way has: 50 billion. Fifty billion in scientific notation is 5×10^{10} . To calculate the mass (in gm) of all of the galaxies in the Universe, we need to solve this equation:

$$\text{Mass of Galaxies in Universe} = (\# \text{ of Galaxies}) \times (\text{Average Mass of a Galaxy})$$

You calculated the # of Galaxies in question 7. We need to multiply that number by the Average Mass of a Galaxy. The Average Mass of a Galaxy (in gm) is simply:

$$\text{Average Mass of a Galaxy} = (\# \text{ of stars in a galaxy}) \times (\text{average mass of a star})$$

If the number of stars in a galaxy is 5×10^{10} , and the average mass of a star is 2×10^{33} gm, what is the average mass of a galaxy? (2 points)

$$\text{Average Mass of a Galaxy} = (\underline{\hspace{2cm}}) \times (\underline{\hspace{2cm}})$$

$$= \underline{\hspace{4cm}} \text{ gm}$$

With this number, you can now calculate the total mass of all of the galaxies in the Universe (**2 points**):

$$\text{Mass of Universe} = (\text{_____}) \times (\text{_____}) = \text{_____ gm}$$

11. We have just calculated the total mass of galaxies in the Universe, and are halfway to our goal of figuring out the density of galactic matter in the Universe. Since density = M/V , and we now have M , we have to figure out V , the Volume of the Universe. This is a little more difficult than getting M , so make sure you are confident of your answer to each of the following steps before proceeding to the next. We are going to make some assumptions that will simplify the calculation of V . First off, we will assume that the Universe is a sphere. The volume of a sphere is simply four thirds “pi” R cubed: $V_{\text{sphere}} = 4\pi R^3/3$. To figure out the volume of the Universe we need to calculate “ R ”, the radius of the Universe.

So, how can we estimate R ? In your lecture class you will find out that the most distant parts of the Universe are moving away from us at nearly the speed of light (the observed expansion of the Universe is covered in the Hubble’s Law lab). Let’s assume that the largest distance an object can have in our Universe is given by the speed of light \times the age of the Universe. Remember, if a car travels at 50 mph for one hour it will cover 50 miles: Distance = velocity \times time. We can use this equation to estimate the radius of the Universe: $R_{\text{Universe}} = \text{velocity} \times \text{time} = (\text{speed of light}) \times (\text{age of Universe})$.

The speed of light is a very large number: 3×10^{10} cm/s, and the age of the Universe is also large: 13 billion years. To calculate the radius of the Universe in cm, we must convert the age of the Universe in years to an age in seconds (s). First, how many seconds are there in a year? Let’s do the calculation:

$$\text{Seconds in year} = (\text{seconds in day}) \times (\text{days in year}) = (60 \times 60 \times 24) \times 365 = \text{_____ s/yr}$$

Since this is only estimate, feel free to round off any decimals to whole numbers. Now that we have the number of seconds in a year, we can convert the age of the Universe from years to seconds:

$$\begin{aligned} \text{Age of Universe in seconds} &= (\text{Age of Universe in Years}) \times (\text{seconds in a year}) \\ &= (13 \times 10^9 \text{ yr}) \times \text{_____ s/yr} = \text{_____ s.} \end{aligned}$$

Ok, we now have the “time” part of the equation distance = velocity × time. And we have already set the velocity to the speed of light: 3×10^{10} cm/s. Now we can figure out the Radius of the Universe (**3 points**):

$$\begin{aligned} \text{Radius of Universe (in cm)} &= (\text{speed of light}) \times (\text{Age of Universe in seconds}) = \\ & (3 \times 10^{10} \text{ cm/s}) \times \underline{\hspace{4cm}} \text{ s} = \\ & \underline{\hspace{4cm}} \text{ cm.} \end{aligned}$$

In these calculations, notice how the *units* cancel. The units on a distance or radius is length, and astronomers generally use centimeters (cm) to measure lengths. Velocities have units of length per time, like cm/s. So when calculating a radius in cm, we multiply a velocity with units of cm/s × a time measured in seconds, and the units of seconds cancels, leaving a length unit (cm).

We are now ready to calculate the Volume of the Universe, $V = 4\pi R^3/3$. It may be easier for you to break this into two parts, multiplying out $4/3 \times \pi$, and then taking R^3 , and then multiplying those two numbers. [Remember, $\pi = 3.14$.]

$$\begin{aligned} \text{Volume of Universe} &= 4/3 \times \pi \times R^3 = \\ & \underline{\hspace{4cm}} \times \underline{\hspace{4cm}} = \\ & \underline{\hspace{4cm}} \text{ cm}^3 \end{aligned}$$

12. Tying it all together: figuring out the average density of the Universe (at least that contained within galaxies—astronomers believe there is more “dark” matter in the Universe than the regular matter that we can see contained in galaxies!). We have just calculated the Volume of the Universe, and we have already calculated the Mass of all of the galaxies in the Universe. Now we take the final step, and calculate the Average Galactic Matter Density of the Universe (**3 points**):

$$\begin{aligned} \text{Average Density of the Universe} &= M_{\text{Universe}}/V_{\text{Universe}} = \\ & (\underline{\hspace{4cm}} \text{ gm})/(\underline{\hspace{4cm}} \text{ cm}^3) = \\ & \underline{\hspace{4cm}} \text{ gm/cm}^3 \end{aligned}$$

13. The mass of a single hydrogen atom is 1.7×10^{-24} gm. Compare your answer for the average density of the Universe to the mass of a single hydrogen atom. [Hint: the average amount of mass (*in gm*) of 1 cm^3 of the Universe is simply the density you just calculated, but you drop the cm^3 of the units on density to get *gm*.] Are they similar? What does this imply about the Universe, is it full of stuff, or mostly empty? **(3 points)**

10.5 Summary (35 points)

Please summarize the important concepts discussed in this lab. Your summary should include a brief discussion of

- direct measurement vs. estimation
- error estimates in both direct measurement and estimation
- Consider the importance of the galaxy counting results discussed in lab. Since the Hubble Deep Field was taken in a presumably empty part of the sky, what is the significance of finding so many galaxies in this picture?
- Use the concepts discussed in this lab to estimate the total number of stars that you can see in the night sky by going out at night and doing some counting and estimating. Describe your method as well as the number you get and provide some estimate of your uncertainty in the number.
- Think back to a time before you did this lab, would you have expected the answer to question #13? Our Universe has many surprises!

Use complete sentences, and proofread your summary before handing in the lab.

10.6 Possible Quiz Questions

1. What is meant by the term “estimation”?
2. Why do scientists use estimation?
3. How many degrees are in a circle?
4. What is an “arcminute”?
5. What is the “Hubble Deep Field”?

10.7 Extra Credit (ask your TA for permission before attempting, 5 points)

In question #7, you estimated the number of galaxies in the Universe. In question #10 you found that a typical galaxy contains 50 billion stars. Thus, you can now estimate how many stars there are in the Universe. Recently, some mathematicians have estimated that there are between 7×10^{19} and 7×10^{22} grains of sand on all of the Earth’s beaches—that is every single beach on every single island and continent on the Earth. Obviously, this is a difficult estimate to make, and thus their estimate is quite uncertain. How would you begin to estimate the number of sand grains on the Earth’s beaches? What factors need to be taken into account?

Compare the number of stars in the Universe, with the number of grains of sand on the planet Earth. How do they compare? We still do not know the average number of planets that are found around an average star. It is probably safe to assume that 10% of all stars have at least one planet orbiting them. If so, how many planets are there in the Universe?

Name: _____

Date: _____

11 Hubble's Law: Finding the Age of the Universe

11.1 Introduction

In your lecture sessions (or the lab on spectroscopy), you will find out that an object's spectrum can be used to determine the temperature and chemical composition of that object. A spectrum can also be used to find out how fast an object is moving by measuring the Doppler shift. In this lab you will learn how the velocity of an object can be found from its spectrum, and how Hubble's Law uses the Doppler shift to determine the distance scale of the Universe.

- *Goals:* to discuss Doppler Shift and Hubble's Law, and to use these concepts to determine the age of the Universe
- *Materials:* galaxy spectra, ruler, calculator

11.2 Doppler Shift

You have probably noticed that when an ambulance passes by you, the sound of its siren changes. As it approaches, you hear a high, whining sound which switches to a deeper sound as it passes by. This change in pitch is referred to as the Doppler shift. To understand what is happening, let's consider a water bug treading water in a pond, as in Figure 11.1.

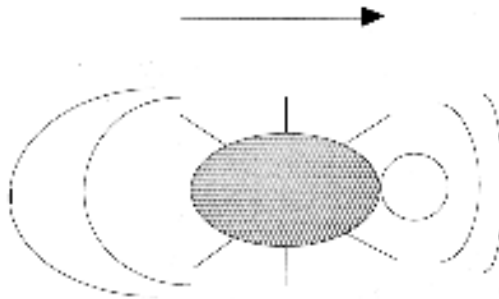

Figure 11.1: A waterbug, treading water.

The bug's kicking legs are making waves in the water. The bug is moving forward relative to the water, so the waves in front of him get compressed, and the waves behind him get stretched out. In other words, the frequency of waves increases in front of him, and decreases behind him. In wavelength terms, the wavelength is shorter in front of him, and longer behind him. Sound also travels in waves, so when the ambulance is approaching you, the frequency is shifted higher, so the pitch (not the volume) is higher. After it has passed you, the frequency is Doppler shifted to a lower pitch as the ambulance moves away from

you. You hear the pitch change because to your point of view the relative motion of the ambulance has changed. First it was moving toward you, then away from you. The ambulance driver won't hear any change in pitch, because for her the relative motion of the ambulance hasn't changed.

The same thing applies to light waves. When a light source is moving away from you, its wavelength is longer, or the color of the light moves toward the red end of the spectrum. A light source moving toward you shows a (color) shift.

This means that we can tell if an object is moving toward or away from us by looking at the change in its spectrum. In astronomy we do this by measuring the wavelengths of spectral lines. We've already learned how each element has a unique fingerprint of spectral lines, so if we look for this fingerprint and notice it is displaced slightly from where we expect it to be, we know that the source must be moving to produce this displacement. We can find out how fast the object is moving by using the Doppler shift formula:

$$\frac{\Delta\lambda}{\lambda_o} = \frac{v}{c}$$

where $\Delta\lambda$ is the wavelength shift you measure, λ_o is the rest wavelength¹ (the one you'd expect to find if the source wasn't moving), v is the radial velocity (velocity toward or away from us), and c is the speed of light (3×10^5 km/s).

In order to do this, you just take the spectrum of your object and compare the wavelengths of the lines you see with the rest wavelengths of lines that you know should be there. For example, we would expect to see lines associated with hydrogen so we might use this set of lines to determine the motion of an object. Here is an example:

Exercise 1. Doppler Shift (10 points)

If we look at the spectrum of a star, we know that there will probably be hydrogen lines. We also know that one hydrogen line always appears at 6563\AA , but we find the line in the star's spectrum at 6570\AA . Let's calculate the Doppler shift:

a) First, is the spectrum of the star redshifted or blueshifted (do we observe a longer or shorter wavelength than we would expect)?

¹For this lab we will be measuring wavelengths in Angstroms. $1.0 \text{\AA} = 1.0 \times 10^{-10} \text{ m}$.

b) Calculate the wavelength shift: $\Delta\lambda = (6570\text{\AA} - 6563\text{\AA})$

$$\Delta\lambda = \text{\AA}$$

c) What is its radial velocity? Use the Doppler shift formula:

$$\frac{\Delta\lambda}{\lambda_o} = \frac{v}{c}$$

$$v = \text{km/s}$$

A way to check your answer is to look at the sign of the velocity. Positive means redshift, and negative means blueshift.

Einstein told us that nothing can go faster than the speed of light. If you have a very high velocity object moving at close to the speed of light, this formula would give you a velocity faster than light! Consequently, this formula is not always correct. For very high velocities you need to use a different formula, the *relativistic* Doppler shift formula, but in this lab we won't need it.

11.3 Hubble's Law

In the 1920's Hubble and Slipher found that there is a relationship between the redshifts of galaxies and how far away they are (don't confuse this with the ways we find distances to stars, which are much closer). This means that the further away a galaxy is, the faster it is moving away from us. This seems like a strange idea, but it makes sense if the Universe is expanding.

The relation between redshift and distance turns out to be very fortunate for astronomers, because it provides a way to find the distances to far away galaxies. The formula we use is known as Hubble's Law:

$$v = H \times d$$

where v is the radial velocity, d is the distance (in Mpc), and H is called the Hubble constant and is expressed in units of $\text{km}/(\text{s} \times \text{Mpc})$. Hubble's constant is basically the expansion

rate of the Universe.

The problem with this formula is that the precise value of H is not known! If we take galaxies of known distance and try to find H , the values range from 50 to 100 km/(s \times Mpc). By using the incredible power of the Hubble Space Telescope, the current value of the H is near 75 km/(s \times Mpc). Let's do an example illustrating how astronomers are trying to determine H .

Exercise 2. The Hubble Constant (15 points)

In this exercise you will determine a value of the Hubble constant based on direct measurements. The figure below has spectra from five different galaxy clusters. At the top of this figure is the spectrum of the Sun for comparison. For each cluster, the spectrum of the brightest galaxy in the cluster is shown to the right of the image of the cluster (usually dominated by a single, bright galaxy). Above and below these spectra, you'll note five, short vertical lines that look like bar codes you might find on groceries. These are comparison spectra, the spectral lines which are produced for elements here on earth. If you look closely at the galaxy spectra, you can see that there are several dark lines going through each of them. The left-most pair of lines correspond to the "H and K" lines from calcium (for the Sun and for Virgo = Cluster #1, these can be found on the left edge of the spectrum). Are these absorption or emission lines? (Hint: How are they appearing in the galaxies' spectra?)

Now we'll use the shift in the calcium lines to determine the recession velocities of the five galaxies. We do this by measuring the change in position of a line in the galaxy spectrum with respect to that of the comparison spectral lines above and below each galaxy spectrum. For this lab, measure the shift in the "K" line of calcium (the left one of the pair) and write your results in the table below (Column B). At this point you've figured out the shift of the galaxies' lines as they appear in the picture. Could we use this alone to determine the recession velocity? No, we need to determine what shift this corresponds to for actual light. In Column C, convert your measured shifts into Ångstroms by using the conversion factor **19.7 Å/mm** (this factor is called the "plate scale", and is similar to the scale on a map that allows you to convert distances from inches to miles—you can determine this yourself using the separation of the H and K lines = 34.8 Å).

Earlier in the lab we learned the formula for the Doppler shift. Your results in Column C represent the values of $\Delta\lambda$. We expect to find the center of the calcium K line at $\lambda_0 = 3933.0 \text{ Å}$. Thus, this is our value of λ . Using the formula for the Doppler shift along with your figures in Column C, determine the recession velocity for each galaxy. The speed of light is, $c = 3 \times 10^5 \text{ km/sec}$. Write your results in Column D. For each galaxy, divide the velocity (Column D) by the distances provided in Column E. Enter your results in Column F.

The first galaxy cluster, Virgo, has been done for you. Go through the calculations for Virgo to check and make sure you understand how to proceed for the other galaxies. **Show all of your work on a separate piece of paper and turn in that paper with your lab.**



The Spectrum of the Sun

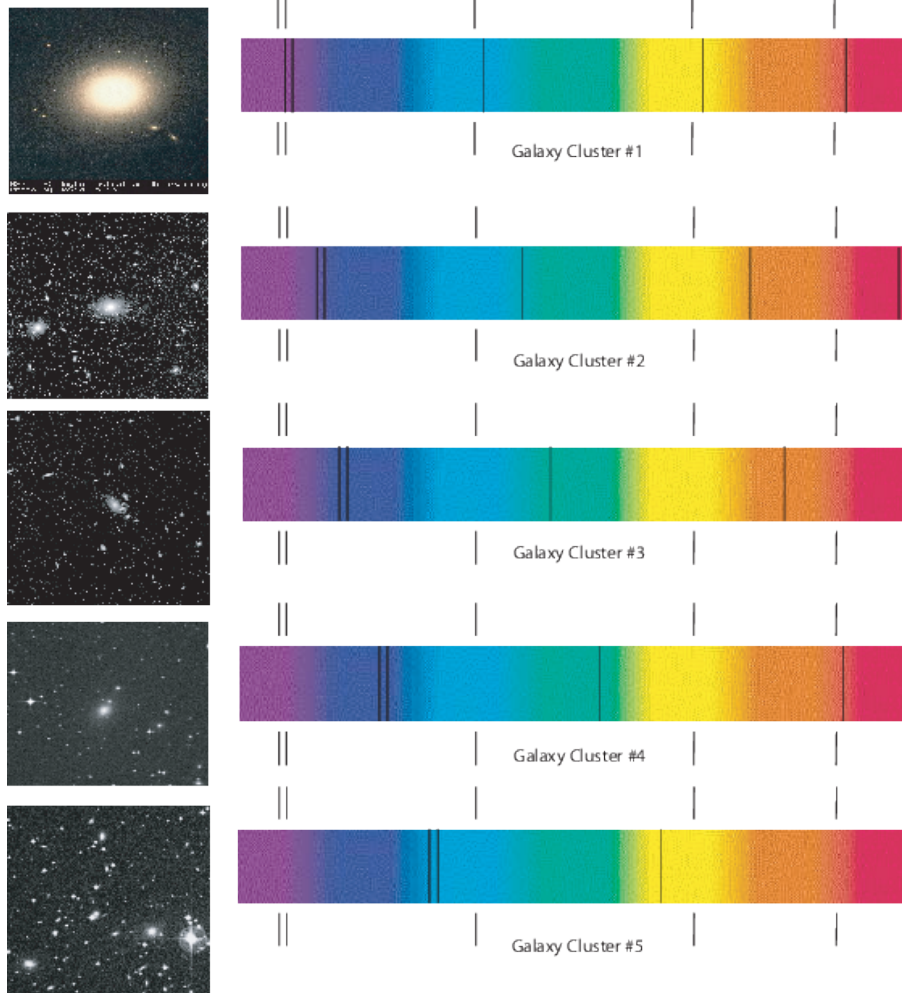

Now we have five galaxies from which to determine the Hubble constant, H . Are your values for the Hubble constant somewhere between 50 and 100 km/(s \times Mpc)? Why do you think that all of your values are not the same? The answer is simple: *human error*. It is only possible to measure the shift in each picture to a certain accuracy. For Virgo the shift is only about 1 mm, but it is difficult with a ruler and naked eye to measure such a small length to a high precision. A perfect measurement would give the “correct” answer (but note that there is always another source of uncertainty: the accuracy of the distances used in this calculation!).

A Galaxy Cluster	B Measured shift (mm)	C Redshift (Angstroms)	D Velocity (km/s)	E Distance (Mpc)	F Value of H (km/s/Mpc)
1. Virgo	<i>0.9</i>	<i>17.7</i>	<i>1,352</i>	20	<i>67.6</i>
2. Ursa Major				110	
3. Corona Borealis				180	
4. Bootes				300	
5. Hydra				490	

11.4 The Age of the Universe

The expansion of the Universe is a result of the Big Bang. Since everything is flying apart, it stands to reason that in the past everything was much closer together. With this idea, we can use the expansion rate to determine how long things have been expanding - in other words, the age of the Universe! As an example, suppose you got in your car and started driving up to Albuquerque. Somewhere around T or C, you look at your watch and wonder what time you left Las Cruces. You know you've driven about 75 miles and have been going 75 miles per hour, so you easily determine you must have left about an hour ago. For the age of the Universe, we essentially do the same thing to figure out how long ago the Universe started. This is assuming that the expansion rate has always been the same, which is probably not true (by analogy, maybe you weren't always driving at 75 mph on your way to T or C). The gravitational force of the galaxies in the Universe pulling on each other would slow the expansion down. However, we can still use this method to get a rough estimate of the age of the Universe.

Exercise 3. Age Calculation (15 points)

The Hubble constant is expressed in units of $\text{km}/(\text{s} \times \text{Mpc})$. Since km and Mpc are both units of distance, we can cancel them out and express H in terms of $1/\text{sec}$. Simply convert the Mpc into km, and cancel the units of distance. The conversion factor is **1 Mpc = 3.086×10^{19} km**.

a) Add up the five values for the Hubble constant written in the table of Exercise 2, and divide the result by five. This represents the average value of the Hubble constant you have determined.

$$H = \frac{\text{km}}{\text{s} \times \text{Mpc}}$$

b) Convert your value of H into units of $1/\text{s}$:

$$H = \frac{1}{\text{s}}$$

c) Now convert this into seconds by inverting it ($1/H$ from part b):

Age of the Universe = s

d) How many years is this? (convert from seconds to years by knowing there are 60 seconds in a minute, 60 minutes in an hour, etc.)

Age of the Universe=yrs

11.5 How Do we Measure Distances to Galaxies and Galaxy Clusters?

In exercise #2, we made it easy for you by listing the distances to each of the galaxy clusters. If you know the distance to a galaxy, and its redshift, finding the Hubble constant is easy. But how do astronomers find these distances? In fact, it is a very difficult problem. Why? Because the further away an object is from us, the fainter it appears to be. For example, if we were to move the Sun out to a distance of 20 pc, it would no longer be visible to the naked eye! Note that the closest galaxy cluster is at a distance of 20 Mpc, a million times further than this! Even with the largest telescopes in the world, we could not see the Sun at such a great distance (and Virgo is the closest big cluster of galaxies).

Think about this question: Why do objects appear to get dimmer with distance? What is actually happening? Answer: The light from a source spreads out as it travels. This is shown in Fig. 11.2. If you draw (concentric) spheres around a light source, the amount of energy passing through a square meter drops with distance as $1/R^2$. Why? The area of a sphere is $4\pi R^2$. The innermost sphere in Fig. 11.2 has a radius of “1” m, its area is therefore $4\pi \text{ m}^2$. If the radius of the next sphere out is “2” m, then its area is $16\pi \text{ m}^2$. It has $4\times$ the area of the inner sphere. Since all of the light from the light bulb passes through both spheres, its intensity (energy/area) must drop. The higher the intensity, the brighter an object appears to our eyes. The lower the intensity, the fainter it appears. Again, refer to Fig. 11.2, as shown there, the amount of energy passing through 1 square of the inner sphere passes through 4 squares for the next sphere out, and 9 squares (for $R = 3$) for the outermost sphere. The light from the light bulb spreads out as it travels, and the intensity drops as $1/R^2$.

Exercise 4. Inverse Square Law If the apparent brightness (or intensity) of an object is proportional to $1/R^2$ (where $R = \text{distance}$), how much brighter is an object in the Virgo cluster, compared to a similar object in Hydra? [Hint: how many times further is Hydra than Virgo?] **(2 points)**

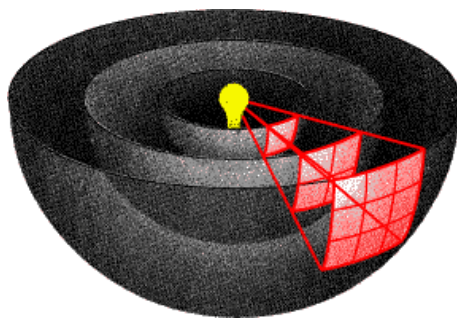

Figure 11.2: If you draw concentric spheres around a light source (we have cut the spheres in half for clarity), you can see how light spreads out as it travels. The light passing through one square on the inner sphere passes through four squares for a sphere that has twice the radius, and nine squares for a sphere that has three times the radius of the innermost sphere. This is because the area of a sphere is $4\pi R^2$.

An object in Hydra is hundreds of times fainter than the same object in Virgo! Obviously, astronomers need to find an object that is very luminous if they are going to measure distances to galaxies that are as far, or even further away than the Hydra cluster. You have probably heard of a supernova. Supernovae (supernovae is the plural of supernova) are tremendous explosions that rip stars apart. There are two types of supernova, Type I is due to the collapse of a white dwarf into neutron star, while a Type II is the explosion of a massive star that often produces a black hole. Astronomers use Type I supernovae to measure distances since their explosions always release the same amount of energy. Type I supernovae have more than one billion times the Sun's luminosity when they explode! Thus, we can see them a long way.

Let's work an example. In 1885 a supernova erupted in the nearby Andromeda galaxy. Andromeda is a spiral galaxy that is similar in size to our Milky Way located at a distance of about 1 Mpc. The 1885 supernova was just barely visible to the naked eye, but would have been easy to see with a small telescope (or even binoculars). Astronomers use telescopes to collect light, and see fainter objects better. The largest telescopes in the world are the Keck telescopes in Hawaii. These telescopes have diameters of 10 meters, and collect 6 million times as much light as the naked eye (thus, if you used an eyepiece on a Keck telescope, you could "see" objects that are 6 million times fainter than those visible to your naked eye).

Using the fact that brightness decreases as $1/R^2$, how far away (in Mpc) could the Keck telescope see a supernova like the one that blew up in the Andromeda galaxy? (**2 points**). [Hint: here we reverse the equation. You are given the brightness ratio, 6 million, and must solve for the distance ratio, remembering that Andromeda has a distance of 1 Mpc!]

Could the Keck telescopes see a supernova in Hydra? **(1 point)**

11.6 Questions

1. Explain how the Doppler shift works. **(5 points)**
2. In the water bug analogy, we know what happens to waves in front of and behind the bug, but what happens to the waves directly on his left and right (hint: is the bug's motion compressing these waves, stretching them out, or not affecting them at all)? With this in mind, what can the Doppler shift tell us about the motion of a star which is moving only at a right angle to our line of sight? **(5 points)**
3. Why did we use an average value for the Hubble constant, determined from five separate galaxies, in our age of the Universe calculation? What other important factor in our determination of the age of the Universe did we overlook? (Hint: It was mentioned in the lab.) **(5 points)**
4. Does the age of the Universe that you calculated seem reasonable? Check your textbook or the World Wide Web for the ages estimated for globular clusters, some of the oldest known objects in the Universe. How does our result compare? Can any object in the Universe be older than the Universe itself? **(5 points)**

11.7 Summary (35 points)

Summarize what you learned from this lab. Your summary should include:

- An explanation of how light is used to find the distance to a galaxy
- From the knowledge you have gained from the last several labs, list and explain *all* of the information that can be found in an object's spectrum.

Use complete sentences, and proofread your summary before handing in the lab.

Possible Quiz Questions

- 1) What is a spectrum, and what is meant by wavelength?
- 2) What is a redshift?
- 3) What is the Hubble expansion law?

11.8 Extra Credit (ask your TA for permission before attempting, 5 points)

Recently, it has been discovered that the rate of expansion of the Universe appears to be accelerating. This means that the Hubble “constant” is not really constant! Using the world wide web, or recent magazine articles, read about the future of the Universe if this acceleration is truly occurring. Write a short essay summarizing the fate of stars and galaxies in an accelerating Universe.

12 APPENDIX A: Fundamental Quantities

There are various ways to describe the world in which we live. Some are qualitative and others are quantitative. Qualitative descriptions describe aspects of objects or events such as texture, and use words like ‘rough’, ‘smooth’, ‘flat’ etc. Qualitative descriptions cannot be described numerically. One would not say that you looked tired with a value of 3.0 unless someone had first set up some kind of numerical scale to measure just how tired you were; tiredness is not something we measure quantitatively. On the other hand, length is a dimension that can be described either qualitatively or quantitatively; one can qualitatively describe an object as long, or one can quantitatively describe it as 10 feet in length.

All quantitative measurements are made in some kind of unit. Length, for example, can be measured in units of meters, feet, miles, etc. Other fundamental metric units are the kilogram (a measure of mass) and the second (a unit of time). Other units of measurement are combinations of these fundamental units. An example of a combination is velocity, expressed in units of meters per second (m/s) which measures how far something has moved in a given direction over a given period of time.

In astronomical studies, one sometimes uses units which express rather large values in the fundamental metric units. An example of this would be the Solar Mass unit (notated as M_{\odot}). The mass of our Sun is, by definition, one Solar Mass or about 1,900,000,000,000,000,000,000,000 kilograms. A star with 10 times as much mass can be written as $10 M_{\odot}$; this is clearly more convenient to write than a number with all those zeros! Other units used in astronomy are the light year (ly), parsec (pc), and the astronomical unit (A.U.), all of which are units of distance. The unit you choose to use depends on the situation, and personal preferences. When describing distances in the solar system the astronomical unit is typically used since it is the average distance from the Sun to the Earth. In describing distances to stars the parsec or light year is usually used.

As described in the introductory lab, the metric system allows easy expression of large multiples of the fundamental units via prefixes. For example, 1,000 meters is called a kilometer and is usually written as 1km.

As described in section 1.4 scientists also use a notation system called scientific notation for representing very large or very small numbers without having to write lots of digits. As an example of how large numbers can get in science let’s look at the mass of Mars. Using Kepler’s laws of motion to study Mars’ moons, astronomers have determined that Mars has a mass approximately equal to 640,000,000,000,000,000,000 kilograms. Now you can see that it is rather inconvenient to write down all those zeroes, and it is confusing to use the prefixes above. Imagine how much more mass there is in the Galaxy and you can see that we need an easy way to write very big (or very small) numbers. This leads us to the concept of Scientific Notation.

13 APPENDIX B: Accuracy and Significant Digits

The number of significant digits in a number is the number of non-zero digits in the number. For example, the number 12.735 has *five* significant digits; the number 100 has *1*. When computing numbers, people today often use calculators since they give us precise answers quickly. Unfortunately, many times they give us answers that are unnecessarily and sometimes unrealistically precise. In other words, they give us as many significant digits as can fit on the calculator screen. In most cases, you will not know the numbers you are plugging in to the calculator to this precise of a value, and therefore will get an answer that has too many significant digits to be correct. This will be the case for your astronomy labs this semester. In general, you should only report the accuracy of a calculation with the number of significant digits of the least certain (smallest number of significant digits) of any of the numbers which were the input into the calculation. For example, if you are dividing 13.2 by 6.8, although your calculator gives 1.94117647, you should only report two significant figures (i.e. 1.9), since that is the number of significant figures in the input number 6.8.

14 APPENDIX C: Unit Conversions

Very often, scientists convert numbers from one set of units to another. In fact, not only do scientists do this, but you do it as well! For example, if someone asks you how tall you are, you could tell them your height in feet or even in inches. If someone said they are 72 inches tall, and 12 inches equals 1 foot, then you know they are 6 feet tall! This is nothing more than a simple conversion from units of inches to units of feet. Another everyday unit conversion is from minutes to hours, and vice versa. If it takes you 30 minutes to drive from Las Cruces to Anthony, then it takes you 0.5 hours. We know this because 60 minutes are equal to 1 hour. However, how can we write these unit conversions, with all the steps, so that we are sure we are converting units correctly (especially when the units are foreign to us (i.e. parsecs, AU, etc.))?

Let us begin with our everyday conversion of inches to feet. Say a person informs you that they are 72 inches tall and you want to know how many feet tall they are. First, we need to know the unit conversion from inches to feet (12 inches = 1 foot). We then write the following equation:

$$72 \text{ inches} \times \frac{1 \text{ foot}}{12 \text{ inches}} = 6 \text{ feet} \quad (6)$$

Note how the inches units cancel (one in the numerator and one in the denominator) and the units which remain are feet. As for the mathematics, simply use normal rules of division ($72/12 = 6$) and you wind up with the correct result.

The second example, minutes to hours, can be performed using the method above, but what if someone asked you how many days there are in 30 minutes? You will need to use 2 unit conversions to do this (60 minutes = 1 hours, 24 hours = 1 day). Here is how you may perform the unit conversion:

$$30 \text{ minutes} \times \frac{1 \text{ hour}}{60 \text{ minutes}} \times \frac{1 \text{ day}}{24 \text{ hours}} \approx 0.0208 \text{ days} = 2.08 \times 10^{-2} \text{ days} \quad (7)$$

Again, note that the minute units have cancelled as well as the hour units, leaving only days.

You have now seen how to perform single and multiple unit conversions. The key to performing these correctly is to 1) make sure you have all the conversion factors you need, 2) write out all of the steps and make sure the units cancel, and 3) think about your final result and ask whether the final result makes sense (is 30 minutes a small fraction of a day? Does 72 inches equal 6 feet?).

15 APPENDIX D: Uncertainties and Errors

A very important concept in science is the idea of uncertainties and errors. Whenever measurements are made, they are never made absolutely perfectly. For example, when you measure your height, you probably measure it only to roughly the nearest tenth of an inch or so. No one says they are exactly 71.56789123 inches tall, for example, because they don't make the measurement this accurately. Similarly, if someone says they are 71 inches tall, we don't really know that they are exactly 71 inches tall; they may, for example, be 71.002 inches tall, but their measurement wasn't accurate enough to draw this distinction.

In astronomy, since the objects we study are so far away, measurements can be very hard to make. As a result, the uncertainties of the measurements can be quite large. For example, astronomers are still trying to refine measurements of the distance to the nearest galaxy. At the current time, we think the distance is about 160,000 light years, but the uncertainty in this measurement is something like 20,000 light years, so the true distance may be as little as 140,000 light years or as much as 180,000 light years. When you do science, you have to always assess the errors on your measurements.

16 Observatory Worksheets

You *must* visit campus observatory twice this semester. You will need to take four of the observatory worksheets with you each time you go.

Campus Observatory Observation Sheet

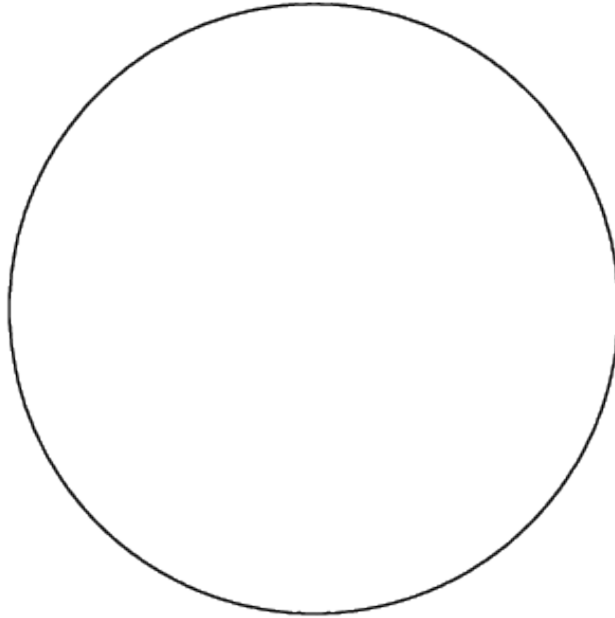

Your Name: _____ T.A.: _____

Date & Time: _____ Telescope: _____

Type of Object: _____ Object Name: _____

Object Description: _____

Fact about this object (and the source of information):

Campus Observatory Observation Sheet

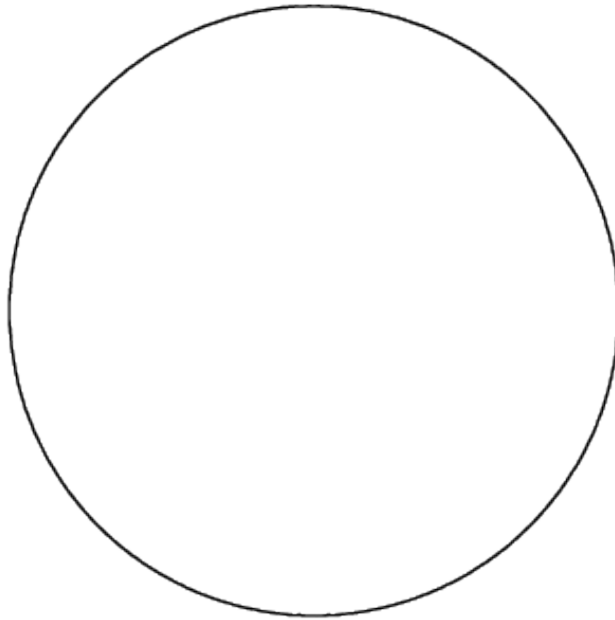

Your Name: _____ T.A.: _____

Date & Time: _____ Telescope: _____

Type of Object: _____ Object Name: _____

Object Description: _____

Fact about this object (and the source of information):

Campus Observatory Observation Sheet

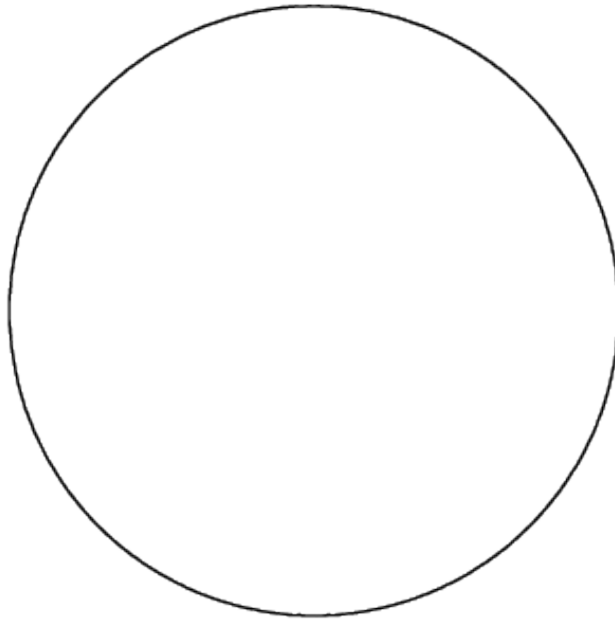

Your Name: _____ T.A.: _____

Date & Time: _____ Telescope: _____

Type of Object: _____ Object Name: _____

Object Description: _____

Fact about this object (and the source of information):

Campus Observatory Observation Sheet

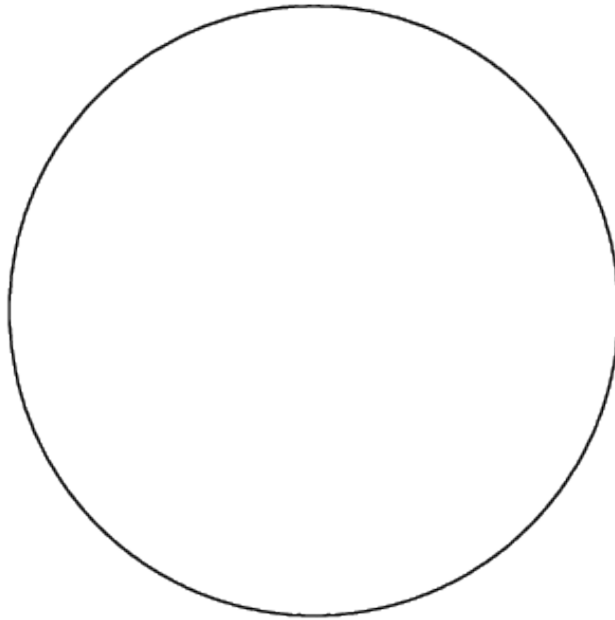

Your Name: _____ T.A.: _____

Date & Time: _____ Telescope: _____

Type of Object: _____ Object Name: _____

Object Description: _____

Fact about this object (and the source of information):

Campus Observatory Observation Sheet

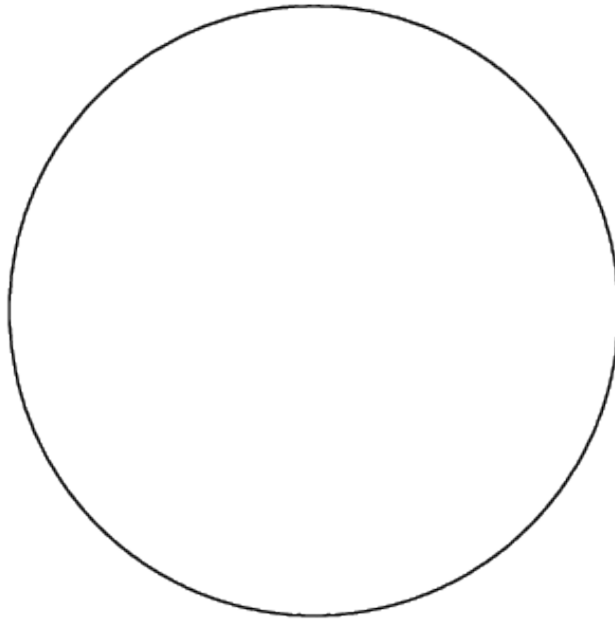

Your Name: _____ T.A.: _____

Date & Time: _____ Telescope: _____

Type of Object: _____ Object Name: _____

Object Description: _____

Fact about this object (and the source of information):

Campus Observatory Observation Sheet

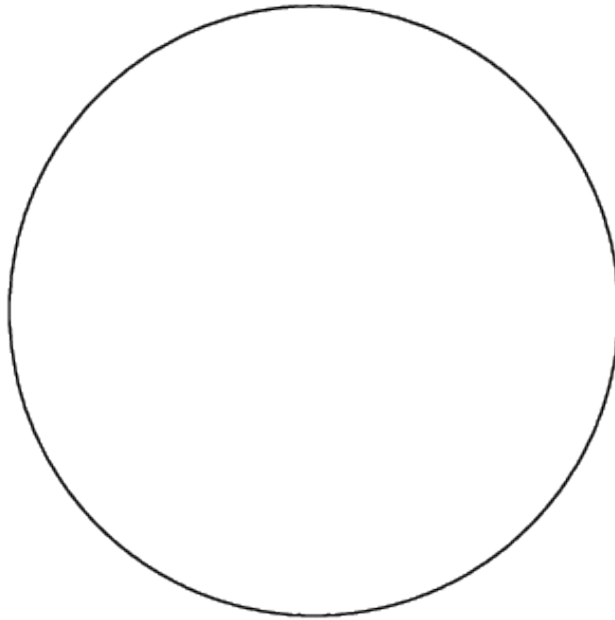

Your Name: _____ T.A.: _____

Date & Time: _____ Telescope: _____

Type of Object: _____ Object Name: _____

Object Description: _____

Fact about this object (and the source of information):

Campus Observatory Observation Sheet

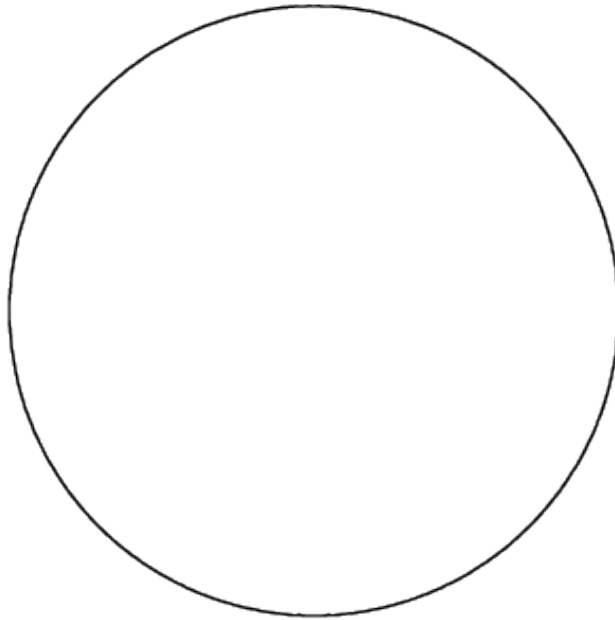

Your Name: _____ T.A.: _____

Date & Time: _____ Telescope: _____

Type of Object: _____ Object Name: _____

Object Description: _____

Fact about this object (and the source of information):

Campus Observatory Observation Sheet

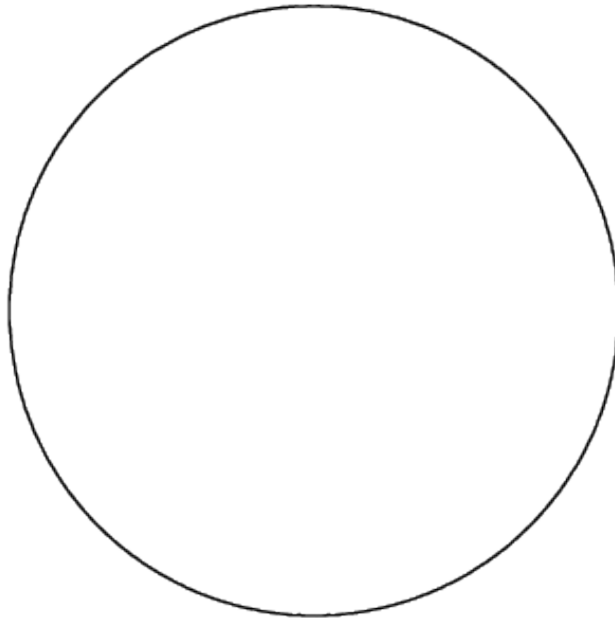

Your Name: _____ T.A.: _____

Date & Time: _____ Telescope: _____

Type of Object: _____ Object Name: _____

Object Description: _____

Fact about this object (and the source of information):
